



Hali-Brite® Segmented Circle HB-5340

FAA Compliant, Made in America.
Pre-assembled segments for easy installation



Features

- FAA Compliant, Buy American Qualified
- Pre-assembled panels for easy Installation
- Collapsible panels- ships on 4 pallets
- Custom design for your submittal
- Available in 8', 10' or 12' segments
- Long lasting, aluminum powder coated panels
- Compliant to FAA AC Circular 150/5340-5D

FAA Compliant to AC 150/5340-5D
SEGMENTED CIRCLE AIRPORT MARKER SYSTEM

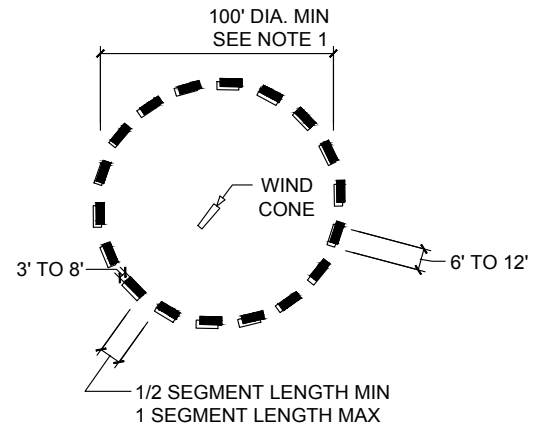

Typical 10' Model Layout

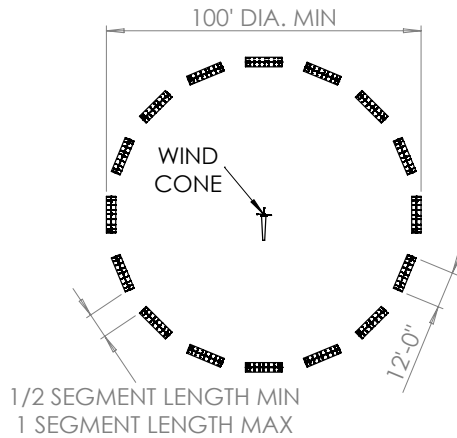

Typical 12' Model Layout

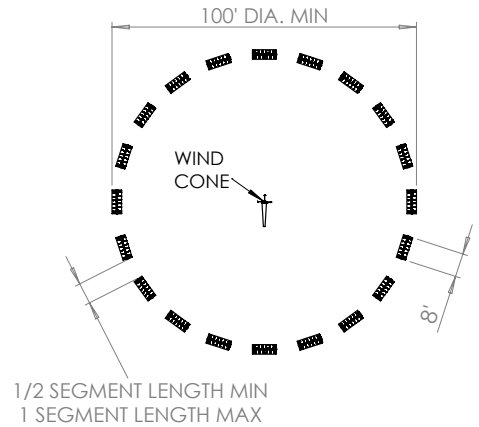

Typical 8' Model Layout

3 SEGMENTED CIRCLE MARKER AND WIND DIRECTION INDICATOR
 1" = 1'-0"

Sales and Technical Support:
 1.800.553.6269
 Sales@halibrite.com

Hali-Brite, Inc.
 1119 Madison Street
 Brainerd, MN 56401

www.halibrite.com
 Ph: 218.454.0956
 Fax: 218.454.0972



Hali-Brite® Segmented Circle HB-5340

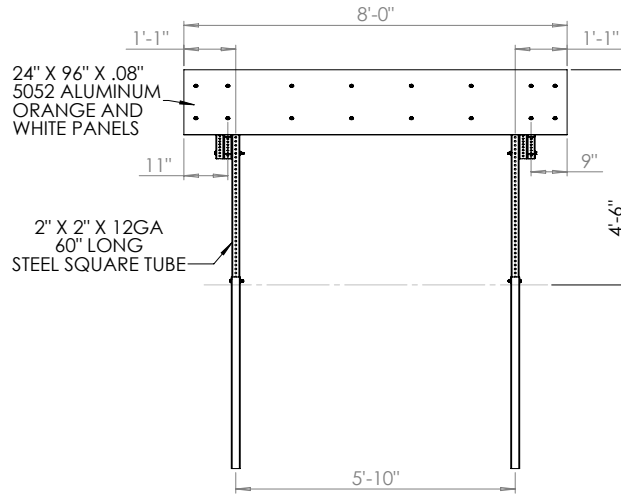
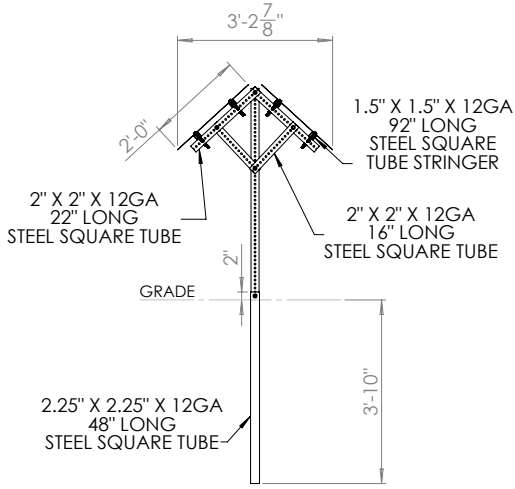

**Hali-Brite®
Model
HB-5340-8-2**

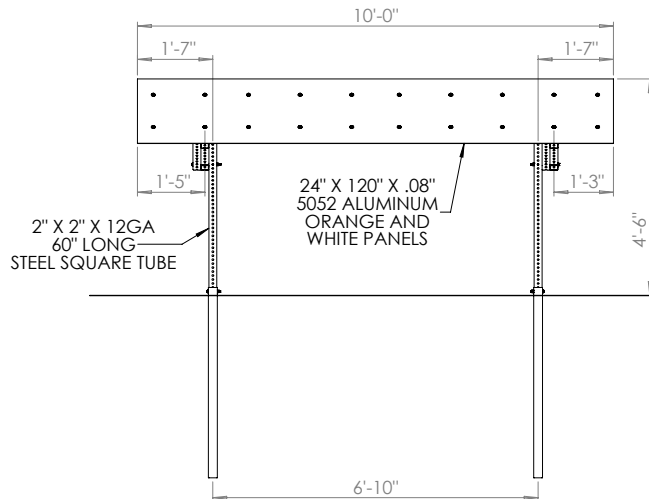
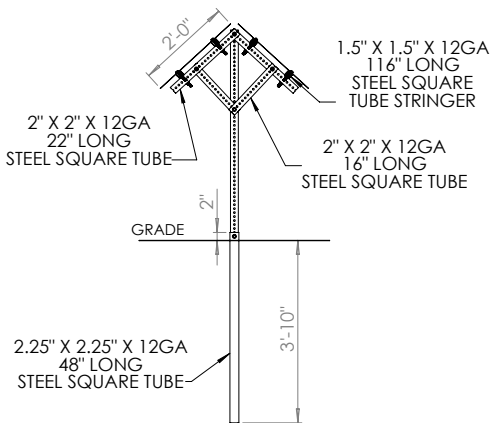

**Hali-Brite®
Model
HB-5340-10-2**

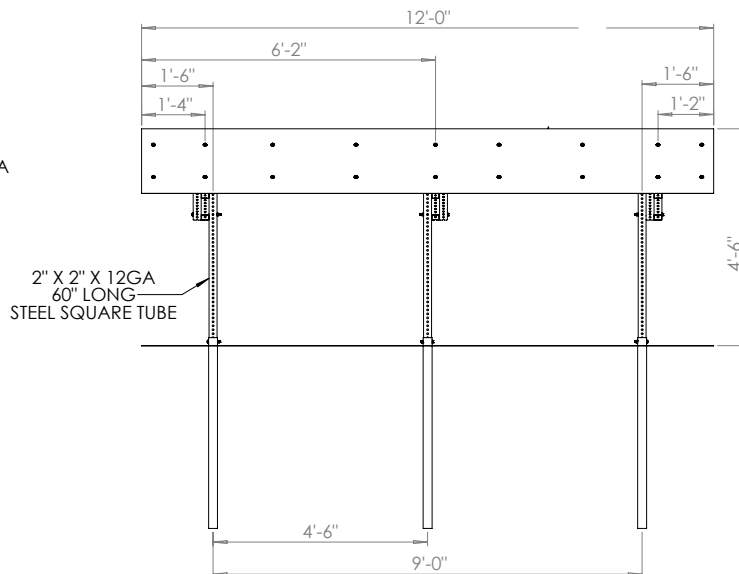
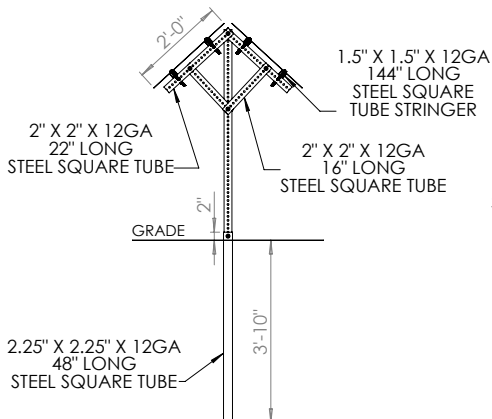

**Hali-Brite®
Model
HB-5340-12-3**

HB-5340 SEGMENTED
CIRCLE 8'

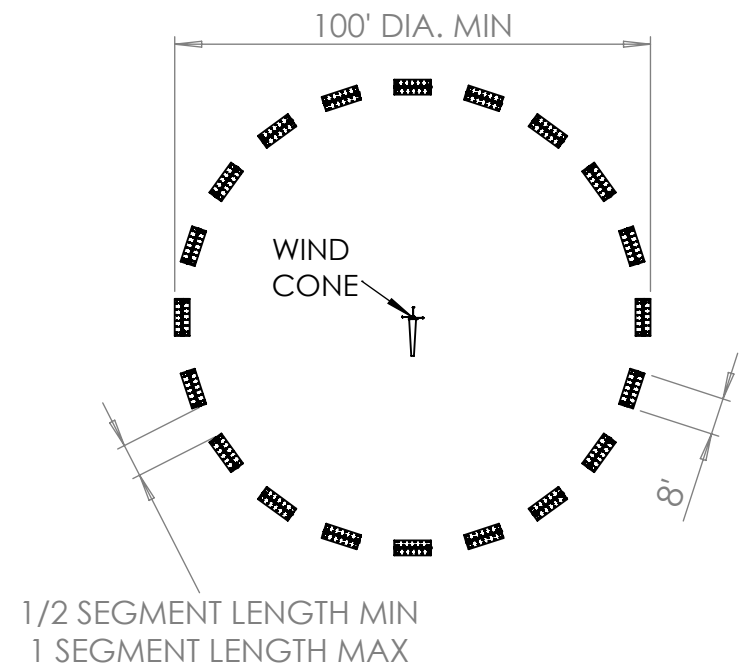
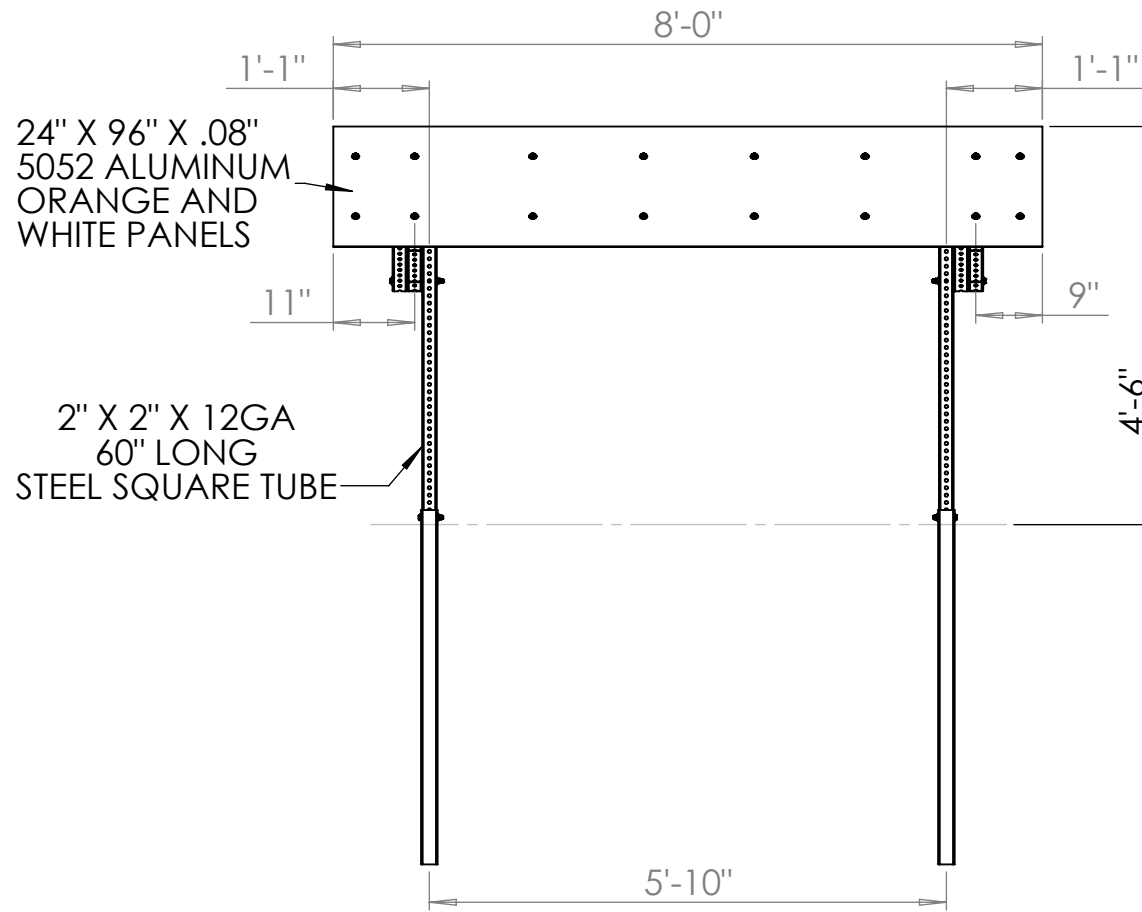
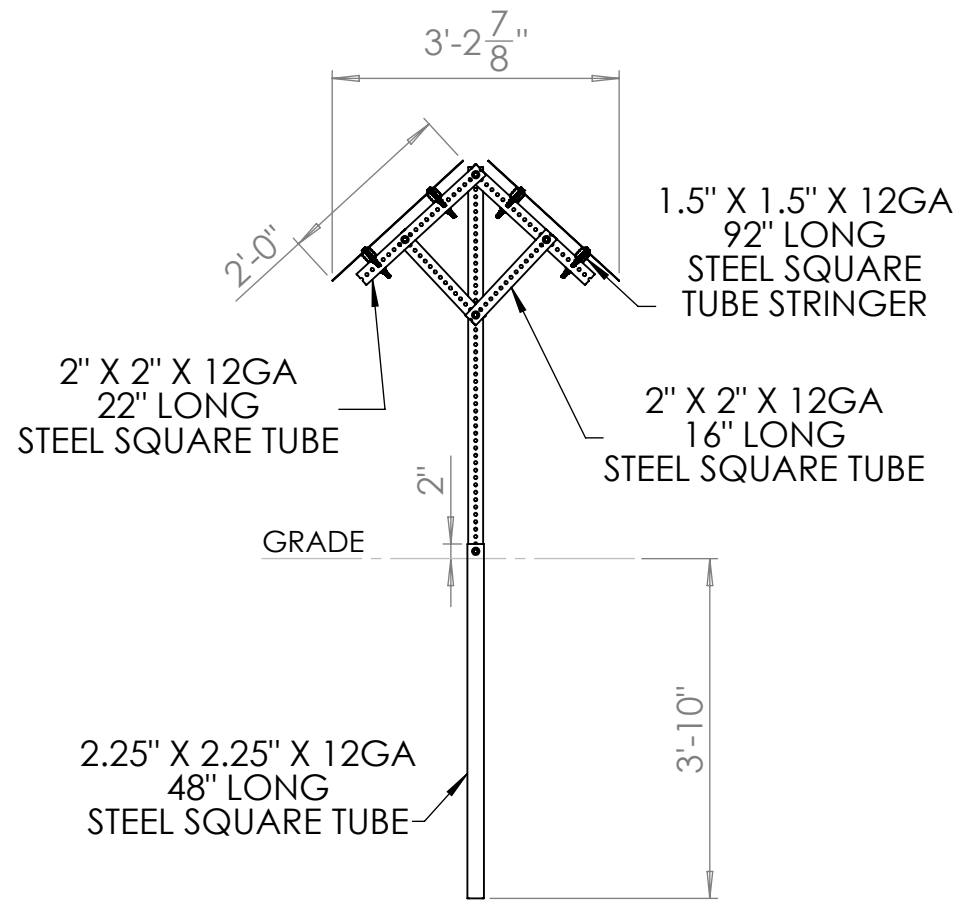

TOLERANCES UNLESS OTHERWISE SPECIFIED	ONE DECIMAL	± .05
	TWO DECIMAL	± .015
	THREE DECIMAL	± .005
	ANGULAR	± 2°



THIRD ANGLE
PROJECTION



DRAWN	SDN	DATE	10/20/2022
-------	-----	------	------------

WELD	N/A
FINISH	N/A
MATERIAL	

0100-3876

DO NOT
SCALE DRAWING

SHEET 1 OF 1

HB-5340 SEGMENTED
CIRCLE 8'

WARNING THE EXPORT AND REEXPORT OF THIS DRAWING OR A PRODUCT PRODUCED BY THIS DRAWING IS SUBJECT TO U.S. EXPORT ADMINISTRATION REGULATIONS AND OTHER APPLICABLE GOVERNMENT RESTRICTIONS OR REGULATIONS.	COPYRIGHT © ORIGINALLY CREATED AND REVISED IN THE YEARS AS IDENTIFIED IN THE RELEASING ECN. HALI-BRITE INC. RESERVES ALL RIGHTS.	PROPRIETARY NOTICE THIS DOCUMENT CONTAINS CONFIDENTIAL AND TRADE SECRET INFORMATION, IS THE PROPERTY OF HALI-BRITE INC., AND IS GIVEN TO THE RECEIVER IN CONFIDENCE. THE RECEIVER, BY RECEPTION AND RETENTION OF THE DOCUMENT, ACCEPTS THE DOCUMENTS IN CONFIDENCE AND AGREES THAT, EXCEPT AS AUTHORIZED IN WRITING BY HALI-BRITE INC., IT WILL (1) NOT USE THE DOCUMENT OR ANY COPY THEREOF OR THE CONFIDENTIAL OR TRADE SECRET INFORMATION THEREIN; (2) NOT COPY THE DOCUMENT, (3) NOT DISCLOSE TO OTHERS EITHER THE DOCUMENT OR THE CONFIDENTIAL OR TRADE SECRET INFORMATION THEREIN; AND (4) UPON COMPLETION OF THE NEED TO RETAIN THE DOCUMENT, OR UPON DEMAND, RETURN OF THE DOCUMENT, ALL COPIES THEREOF, AND ALL MATERIALS COPIED THERE FROM.
---	--	--

HB-5340 SEGMENTED
CIRCLE 10' - 2 LEGS

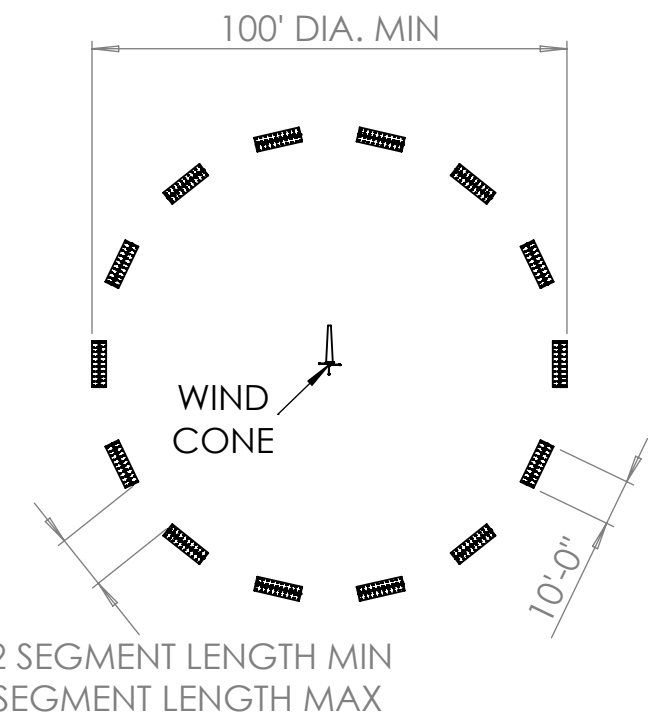
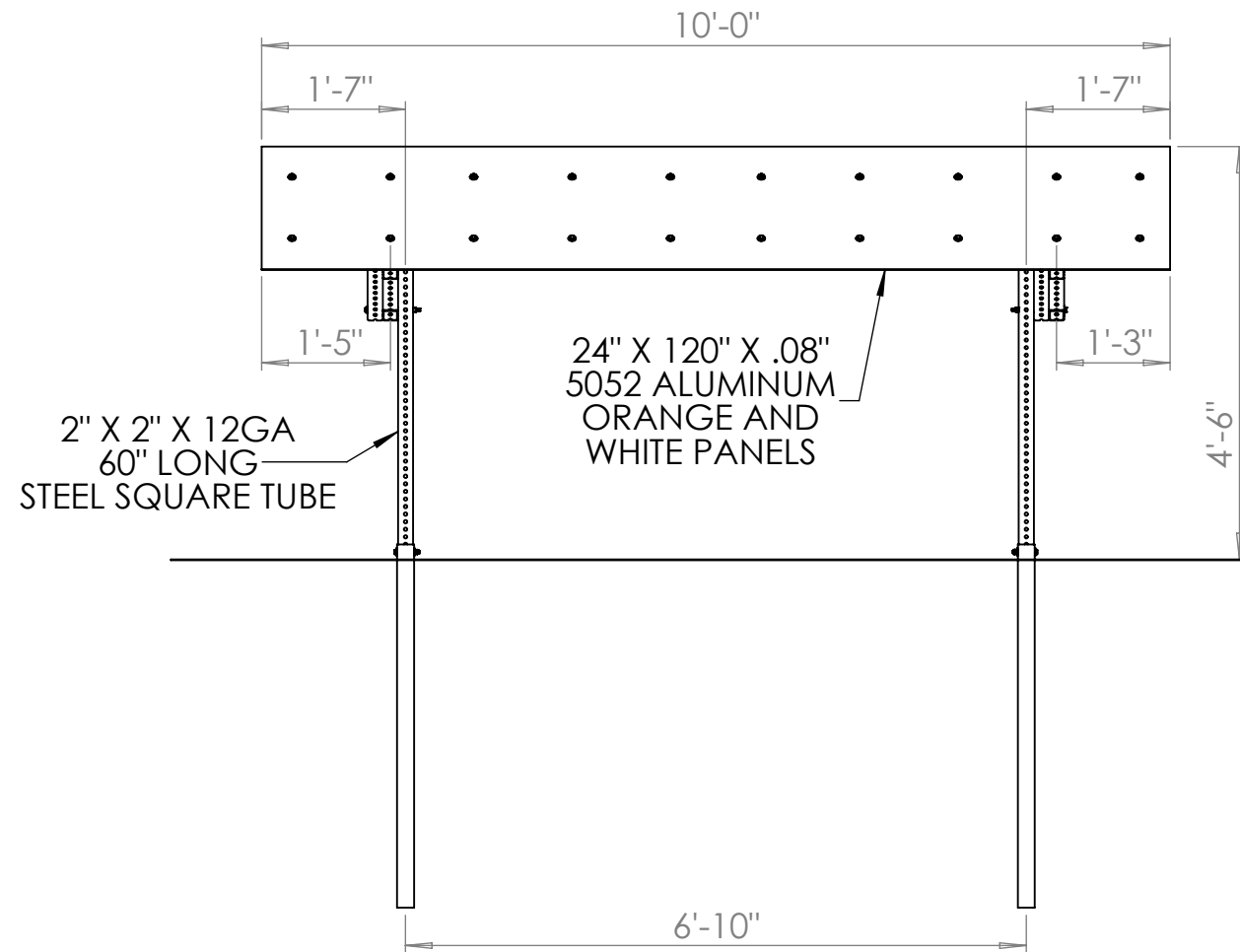
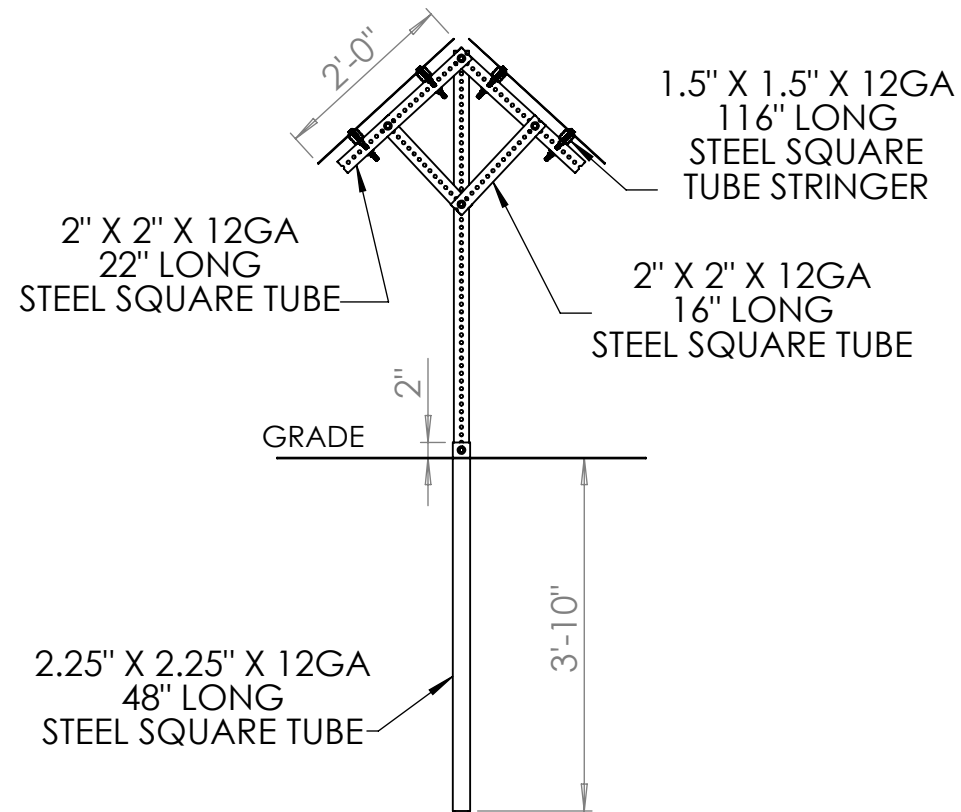

TOLERANCES UNLESS OTHERWISE SPECIFIED	ONE DECIMAL	± .05
	TWO DECIMAL	± .015
	THREE DECIMAL	± .005
	ANGULAR	± 2°



DRAWN SDN DATE 12/15/2022

WELD
N/A
FINISH
N/A
MATERIAL

0100-3876

DO NOT
SCALE DRAWING

SHEET 1 OF 1

HB-5340 SEGMENTED CIRCLE
10' - 2 LEGS

WARNING THE EXPORT AND REEXPORT OF THIS DRAWING OR A PRODUCT PRODUCED BY THIS DRAWING IS SUBJECT TO U.S. EXPORT ADMINISTRATION REGULATIONS AND OTHER APPLICABLE GOVERNMENT RESTRICTIONS OR REGULATIONS.	COPYRIGHT © ORIGINALLY CREATED AND REVISED IN THE YEARS AS IDENTIFIED IN THE RELEASING ECN. HALI-BRITE INC. RESERVES ALL RIGHTS.	PROPRIETARY NOTICE THIS DOCUMENT CONTAINS CONFIDENTIAL AND TRADE SECRET INFORMATION, IS THE PROPERTY OF HALI-BRITE INC., AND IS GIVEN TO THE RECEIVER IN CONFIDENCE. THE RECEIVER, BY RECEPTION AND RETENTION OF THE DOCUMENT, ACCEPTS THE DOCUMENTS IN CONFIDENCE AND AGREES THAT, EXCEPT AS AUTHORIZED IN WRITING BY HALI-BRITE INC., IT WILL (1) NOT USE THE DOCUMENT OR ANY COPY THEREOF OR THE CONFIDENTIAL OR TRADE SECRET INFORMATION THEREIN; (2) NOT COPY THE DOCUMENT, (3) NOT DISCLOSE TO OTHERS EITHER THE DOCUMENT OR THE CONFIDENTIAL OR TRADE SECRET INFORMATION THEREIN; AND (4) UPON COMPLETION OF THE NEED TO RETAIN THE DOCUMENT, OR UPON DEMAND, RETURN OF THE DOCUMENT, ALL COPIES THEREOF, AND ALL MATERIALS COPIED THERE FROM.
---	--	--

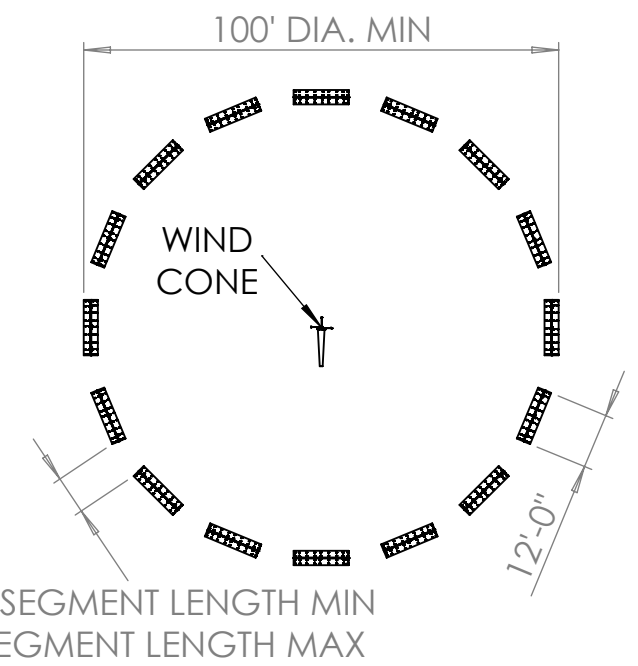
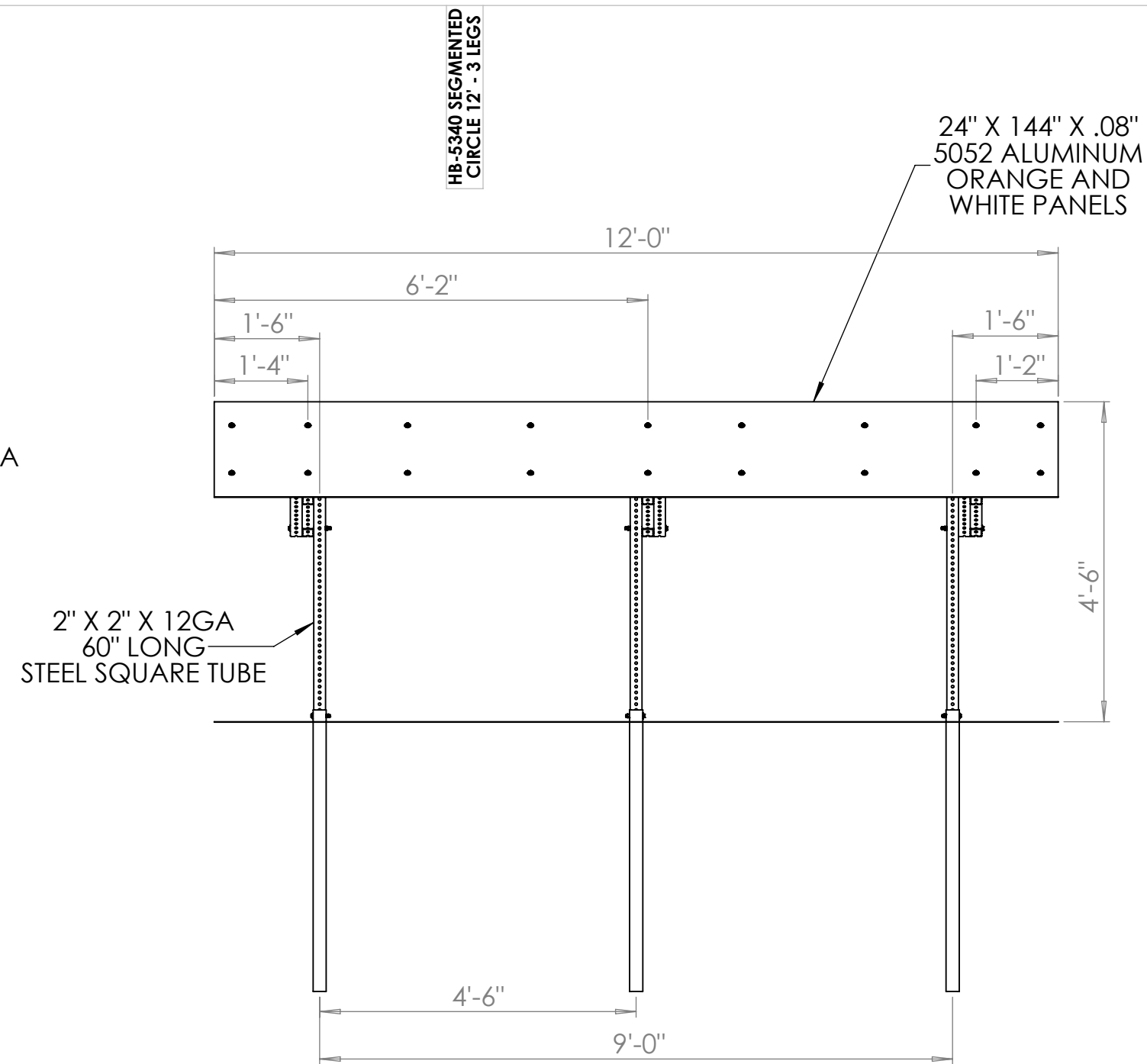
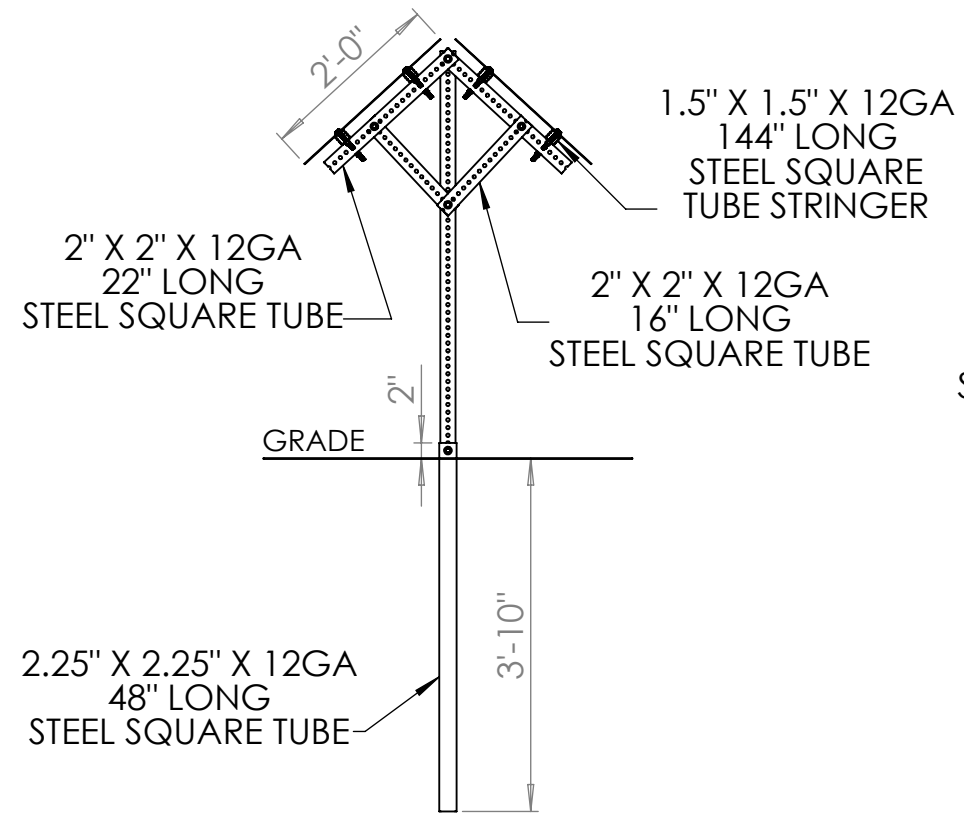

TOLERANCES UNLESS OTHERWISE SPECIFIED	ONE DECIMAL	± .05
	TWO DECIMAL	± .015
	THREE DECIMAL	± .005
	ANGULAR	± 2°



DRAWN	SDN	DATE	1/26/2024
WELD	N/A		
FINISH	N/A		
MATERIAL			

0100-3876

DO NOT SCALE DRAWING

SHEET 1 OF 1

HB-5340 SEGMENTED CIRCLE 12' - 3 LEGS

WARNING THE EXPORT AND REEXPORT OF THIS DRAWING OR A PRODUCT PRODUCED BY THIS DRAWING IS SUBJECT TO U.S. EXPORT ADMINISTRATION REGULATIONS AND OTHER APPLICABLE GOVERNMENT RESTRICTIONS OR REGULATIONS.	COPYRIGHT © ORIGINALLY CREATED AND REVISED IN THE YEARS AS IDENTIFIED IN THE RELEASING ECN. HALI-BRITE INC. RESERVES ALL RIGHTS.	PROPRIETARY NOTICE THIS DOCUMENT CONTAINS CONFIDENTIAL AND TRADE SECRET INFORMATION, IS THE PROPERTY OF HALI-BRITE INC., AND IS GIVEN TO THE RECEIVER IN CONFIDENCE. THE RECEIVER, BY RECEPTION AND RETENTION OF THE DOCUMENT, ACCEPTS THE DOCUMENTS IN CONFIDENCE AND AGREES THAT, EXCEPT AS AUTHORIZED IN WRITING BY HALI-BRITE INC., IT WILL (1) NOT USE THE DOCUMENT OR ANY COPY THEREOF OR THE CONFIDENTIAL OR TRADE SECRET INFORMATION THEREIN; (2) NOT COPY THE DOCUMENT, (3) NOT DISCLOSE TO OTHERS EITHER THE DOCUMENT OR THE CONFIDENTIAL OR TRADE SECRET INFORMATION THEREIN; AND (4) UPON COMPLETION OF THE NEED TO RETAIN THE DOCUMENT, OR UPON DEMAND, RETURN OF THE DOCUMENT, ALL COPIES THEREOF, AND ALL MATERIALS COPIED THERE FROM.
---	--	--