



Hali-Brite®

Installation and Maintenance Manual

Wind Cones L-807, L807(L), L-806, L-806(L) Wind Cones

Hali-Brite®, Inc.
1119 Madison St
Brainerd, MN 56401

1-800-553-6269
www.halibrite.com

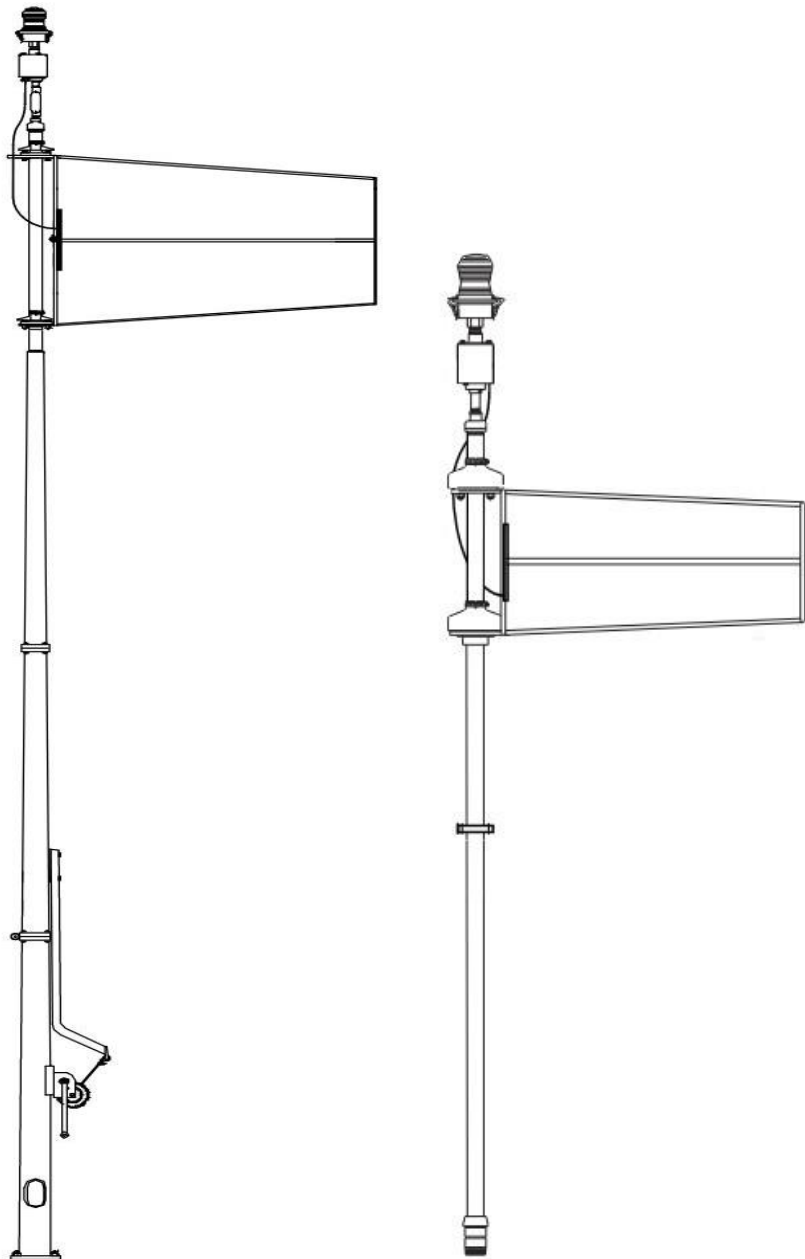

REVISION Number	REVISION Date	Changes
19	Jan 2023	Revised all part numbers and updated L806 to Hinged pole, L807 to pole with additional break
20	Nov 2024	Added specifications on # of turns/, part #s on pg11

Table of Contents

	<i>Introduction</i>	
CHAPTER	About This Manual	4
	Model Configurations	4
	Reference Material	5
	Warranty	5
	Disclaimers	6
CHAPTER 2	<i>Safety Precautions</i>	
	Safety Statements	7
	General Practices	8
	Electrical Practices	9
	Qualified Personnel	9
	Proper Usage	10
CHAPTER 3	<i>Specifications</i>	
	Electrical Specifications	11
	Physical Specifications	11
CHAPTER 4	<i>Getting Started</i>	
	Shipping and Unpacking	15
	Taking Inventory	16
	Tools and Supplies Needed	18

CHAPTER 5

Installing the L-807 Wind Cone

Installing the L-807 Wind Cone Anchor20
Positioning the Swing Arm23
Placing the Base of the Pole onto the Anchor24
Attaching the Basket to the Pole26
Installing Lights27
 Installing the External Lighting Kit27
 Installing the Internal Lighting Kit29
Wiring the Lights to the Power Source30
Installing the Wind Sock to the Basket31
Raising the Top Half of the Pole31

CHAPTER 6

Installing the L-806 Wind Cone

Installing Lights33
 Installing the External Lighting Kit 34
 Installing the Internal Lighting Kit 35
Installing the Wind Sock to the Basket36
Assembling the Pole to the Baseplate37
Wiring the Lights to the Power Source37
Attach the Pole Assembly to the Base Can38

CHAPTER 7

Maintaining and Servicing the Wind Cones

Tools Required39
Lowering the Top of the L-807 Pole39
Inspecting Wind Cone Components40
Replacing Lamps41
Replacing an Obstruction Lamp42
Replacing an External Lamp42
Replacing an Internal Lamp42
L806 Replacement part Diagram43
L807 Replacement part Diagram44

CHAPTER 8

Spare Parts

How to Order Parts45
Recommended Spare Parts45

CHAPTER 9

Wiring Diagrams

CHAPTER 1

Introduction

About This Manual

The information in this manual is provided to assist installation and maintenance personnel in the proper installation, upkeep, and maintenance of the L-806, L-806(L), L-807 and L-807(L) Wind Cones. The (L) suffix denotes models with LED lamps. This manual also includes installation and maintenance instructions for all equipment sold as options to the basic unit.

Model Configurations

This manual covers the models listed below:

WIND CONE MODELS

L806 -S1- XX-XXX-XX-XX

↓
 ↓
 ↓ FM= Floor Flange Mount
 ↓ WM= Wall Mount
 ↓ RM= Roof Mount
 ↓ NM= No Mount/by others
 HS= Hinged Steel Pole
 ST= Steel Pole
 HA= Hinged Aluminum Pole
 ↓ AL= Aluminum Pole
 120= 120volt, LED, 14-19watts
 66A= 6.6amp, LED, 52-65watts
 12= 12volt, LED, 6watts
 230= 230/240V 50/60 Hz, 14-21watts
 ↓ NON= Unlighted
 IN= Internally Lighted (FAA Style 1-B)
 EX= Externally Lighted (FAA Style 1-A)
 UN= Unlighted

L807 -XX- XX-XXX

↓
 ↓ 120= 120volt, LED, 14-19watts
 ↓ 66A= 6.6amp, LED, 52-65watts
 ↓ 12= 12volt, LED, 6watts
 ↓ 230= 230/240V 50/60Hz, 14-21watts
 ↓ NON= Unlighted
 IN= Internally Lighted (FAA Style 1-B)
 EX= Externally Lighted (FAA Style 1-A)
 UN= Unlighted
 S1: FAA Size 1 (18" basket throat, 8' long sock)
 S2: FAA Size 2 (36" basket throat, 12' long sock)

- Halogen models available upon request
- L806 "FM" "WM" "RM" "NM" are options and are listed as separate line items on all quotes and sales orders, and are not included in this manual

WARRANTY:

Hali-Brite® products are guaranteed against mechanical, electrical, and physical defects (excluding lamps) for a period of two years from the date of shipment and are guaranteed to be merchantable and fit for the ordinary purposes for which such products are made. In addition, Hali-Brite® products which are FAA certified to Engineering Brief 67D shall have a four year warranty, from date of installation, on the LED lamp(s) and the associated power supply. Hali-Brite® will correct by repair or replacement, at its option, equipment or parts which fail because of mechanical, electrical or physical defects, provided that the goods have been properly handled and stored prior to installation, properly installed and properly operated after installation, and provided further that Buyer gives Hali-Brite® written notice of such defects after delivery of the goods to Buyer. Hali-Brite® reserves the right to examine goods upon which a claim is made. Said goods must be presented in the same condition as when the defect therein was discovered. Hali-Brite® further reserves the right to require the return of such goods to establish any claim. Hali-Brite's obligation under this guarantee is limited to making repair or replacement within a reasonable time after receipt of such written notice and does not include any other costs such as the cost of removal of defective part, installation of repaired product, labor or consequential damages of any kind, the exclusive remedy being to require such new parts to be furnished. Hali-Brite's liability under no circumstances will exceed the contract price of goods claimed to be defective. Any returns under this guarantee are to be on a transportation charges prepaid basis. For products not manufactured by, but sold by Hali-Brite®, warranty is limited to that extended by the original manufacturer. This is Hali-Brite's sole guarantee and warranty with respect to the goods; there are no express warranties or warranties of fitness for any particular purpose or any implied warranties of fitness for any particular purpose or any implied warranties other than those made expressly herein. All such warranties are expressly disclaimed.

Details and values given in this manual are average values and have been compiled with care. They are not binding, however, and Hali-Brite® disclaims any liability for damages or detriments suffered as a result of reliance on the information given herein or the use of products, processes or equipment to which this manual refers. No warranty is made that the use of the information or of the products, processes or equipment to which this manual refers will not infringe any third party's patents or rights. The information given does not release the buyer from making their own experiments and tests.

Disclaimers

This manual is published for informational purposes only and the information provided should not be considered as all-inclusive or covering all contingencies. If further information is required, Hali-Brite Inc. should be contacted.

Sale of the product shown in this manual is subject to Hali-Brite's terms and conditions including, but not limited to, the Hali-Brite® Warranty. Such terms and conditions are available upon request.

Hali-Brite's warranty will not apply to any products which have been "so repaired or altered outside the manufacturer's plants as, in the manufacturer's judgment, to affect its reliability and performance."

No warranties, express or implied, including warranties of fitness for a particular purpose or merchantability, or warranties arising from course or dealing or usage of trade, are made regarding the information, recommendations, and descriptions contained herein. The manufacturer is not responsible and will not be held liable in contract or in tort (including negligence) for any special, indirect or consequential damages, including injury or damage caused to vehicles, contents or persons, by reason of the installation of any Hali-Brite® product or its mechanical or electrical failure.

CHAPTER 2

Safety Precautions

To help you install and maintain this equipment safely and efficiently make sure you read and understand all safety information in this manual prior to performing any procedure. Failure to do so may result in personal injury, property damage, or possible death.

Safety Statements

The following safety statements are used throughout this manual. They will alert you to possible safety hazards and conditions that could result in personal injury, death, or property and equipment damage.



CAUTION: Indicates hazards or unsafe practices which could result in minor personal injury, product, or property damage.



WARNING: Indicates hazards or unsafe practices which could result in severe personal injury or death.



DANGER: Indicates immediate hazards which will result in severe personal injury or death.

General Practices

Read and become familiar with the general safety instructions provided in this section of the manual before installing, operating, maintaining, or repairing this equipment.

- Do not attempt to assemble or install this equipment if it has been damaged from shipping.
- Do not attempt to install or maintain this equipment if you or the equipment is standing in water.
- Only qualified personnel should perform maintenance on this equipment.
- Always use proper tools (as mentioned in this manual) to perform installation and maintenance.
- Use caution when cranking the winch. Always crank slowly and grasp the handle securely.
- Use proper hand and eye protection as needed when installing or maintaining this equipment.
- Make sure you have adequate first aid supplies available when installing this equipment.
- Do not modify this equipment as this could create a safety hazard and void your Hali-Brite® warranty.
- Only use Hali-Brite® replacement parts.
- Read and carefully follow the instructions given throughout this manual for performing specific tasks and working with specific equipment.
- Follow all applicable safety procedures required by your company, industry standards, and government or other regulatory agencies.
- Make sure all equipment is rated and approved for the environment in which you are using it.
- Follow all instructions for installing components and accessories.
- Protect components from damage, wear, and harsh environment conditions.
- Allow ample room for maintenance, wiring accessibility, and cover removal.

Electrical Practices

- Do not attempt to make electrical connections with the power on.
- Disconnect and lock out electrical power before touching any electrical connections. Refer to FAA Advisory Circular AC 150/5340-26.
- Install all electrical connections to local code.
- Use only electrical wire of sufficient gauge and insulation to handle the rated current demand. All wiring must meet local codes.
- Route electrical wiring along a protected path. Make sure it will not be damaged by moving equipment.
- Protect equipment with safety devices as specified by applicable safety regulations.
- If safety devices must be removed for installation, install them immediately after the work is completed and check them for proper functioning.
- Always use rated electrical tools when performing electrical work.
- Always make sure electrical connections are tight.
- Make sure electrical covers are in place after installation.

Qualified Personnel

Qualified personnel are those that are trained and experienced with installing or maintaining Hali-Brite® equipment. Only qualified personnel should install or maintain Hali-Brite® equipment and auxiliary features.

No one should:

- Attempt to install or perform maintenance on this or any Hali-Brite® equipment if they are physically impaired or under the influence of alcohol or non prescription drugs.
- Maintain or install this equipment without correct training, supervision or experience in mechanical or electrical equipment.
- Attempt to maintain or install this equipment without the correct tools as specified in this manual.

Proper Usage

Always use this equipment as specified in this manual. Improper usage may result in serious personal injury, property damage, or possible death.

- Do not modify any equipment that has not been recommended by Hali-Brite®.
- Do not use any replacement parts that are not purchased from Hali-Brite®.
- Hali-Brite® cannot be responsible for injuries or damages resulting from non-standard, unintended applications of its equipment. This equipment is designed and intended only for the purpose described in this manual. Uses not described in this manual are considered unintended uses and may result in serious personal injury, death, or property damage.

CHAPTER 3

Specifications

Part Number	See Notes	FAA Size	FAA Style	Power Source	Lamp Type	VA	Watts	Weight (pounds)
L806-S1-UN-NON		1	II Unlighted	none	None	0	0	45
L806-S1-EX-120		1	I-A External	120 VAC	LED	15	14	58
L806-S1-EX-230	2	1	I-A External	230/240 VAC	LED	15	14	58
L806-S1-EX-66A	3	1	I-A External	6.6 AMP	LED	58	52	57
L806-S1-IN-120		1	I-B Internal	120 VAC	LED	32	19	59
L806-S1-IN-230	2	1	I-B Internal	230/240 VAC	LED	40	21	59
L806-S1-EX-12		1	I-A External	12 VDC	LED	6	6	57
L806-S1-IN-12		1	I-B Internal	12 VDC	LED	6	6	57
L806-S1-IN-66A	3	1	I-B Internal	6.6 AMP	LED	72	65	57
L807-S1-UN-NON		1	II Unlighted	None	None	0	0	187
L807-S1-EX-230	2	1	I-A External	230/240 VAC	LED	15	14	198
L807-S1-EX-66A	3	1	I-A External	6.6 AMP	LED	58	52	197
L807-S1-IN-120		1	I-B Internal	120 VAC	LED	32	19	200
L807-S1-IN-230	2	1	I-B Internal	230/240 VAC	LED	40	21	200
L807-S1-EX-12		1	I-A External	12 VDC	LED	6	6	197
L807-S1-IN-12		1	I-B Internal	12 VDC	LED	6	6	197
L807-S1-IN-66A	3	1	I-B Internal	6.6 AMP	LED	72	65	198
L807-S2-UN-NON		2	II Unlighted	None	None	0	0	199
L807-S2-IN-120		2	I-B Internal	120 VAC	LED	60	32	212
L807-S2-IN-230	2	2	I-B Internal	230/240 VAC	LED	76	36	212
L807-S2-EX-230	2	2	I-A External	230/240 VAC	LED	22	21	210
L807-S2-EX-66A	3	2	I-A External	6.6 AMP	LED	58	52	209
L807-S2-EX-12		2	I-A External	12 VDC	LED	10	10	210
L807-S2-IN-12		2	I-B Internal	12 VDC	LED	10	10	210
L807-S2-IN-66A	4	2	I-B Internal	6.6 AMP	LED	95	88	210

Notes:

1. Power consumption specifications include the L-810 obstruction light
2. This FAA Style is not ETL certified
3. Requires 100 watt L-830 transformer, sold separately.
4. Requires 200 watt L-830 transformer, sold separately.

Additional Specifications:

1. Wind Sock
 - a. Size 1 dimensions: 18 inch throat diameter, 8 foot length
 - b. Size 2 dimensions: 36 inch throat diameter, 12 foot length
 - c. Color: International Orange
2. Pole Material: Steel tubing
3. Temperature Range: -55C to +55C (-67F to +131F)
4. Wind Indication
 - a. Indicates true direction when wind velocity exceeds 3 knots
 - b. Wind sock full extension when wind velocity exceeds 15 knots
5. Dimensions
 - a. Type L-806 and L-806(L): see Figure 2
 - b. Type L-807 and L-807(L): see Figure 1

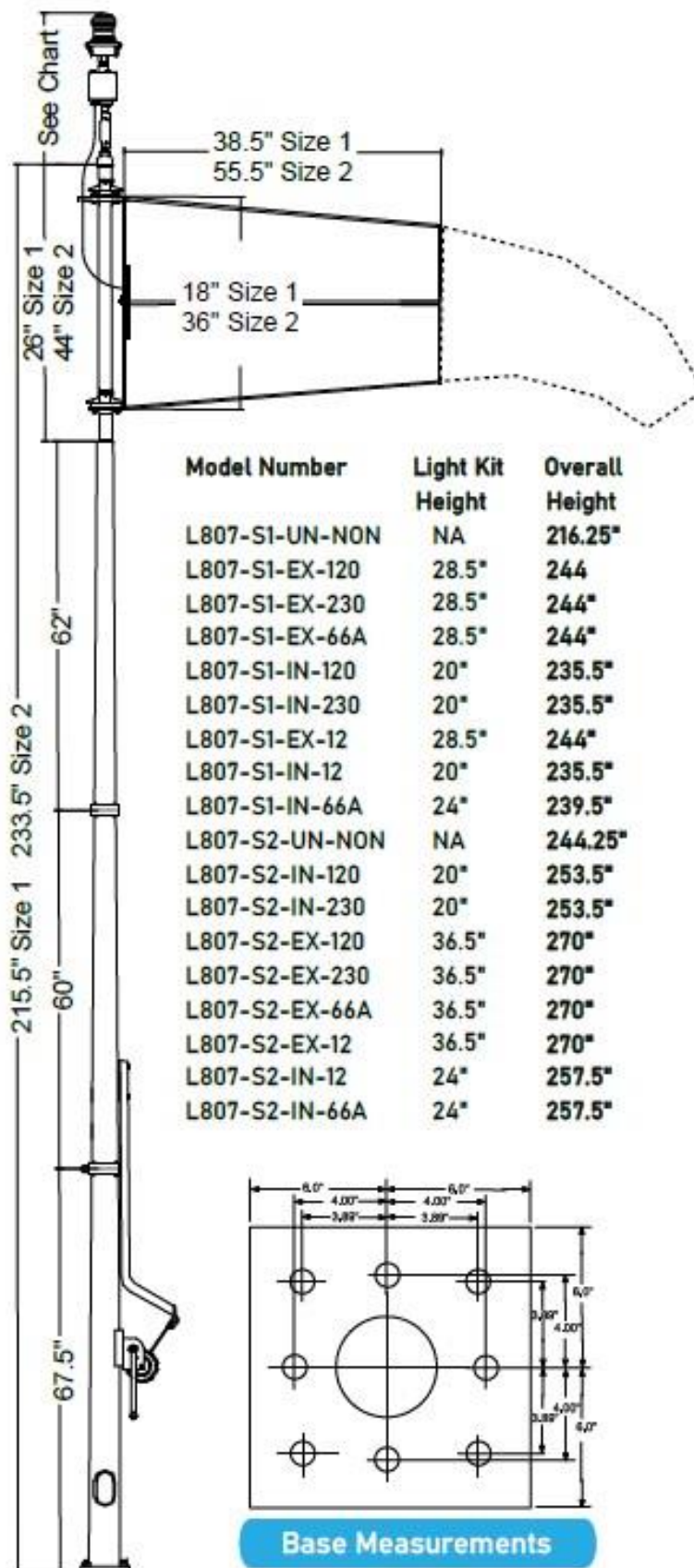
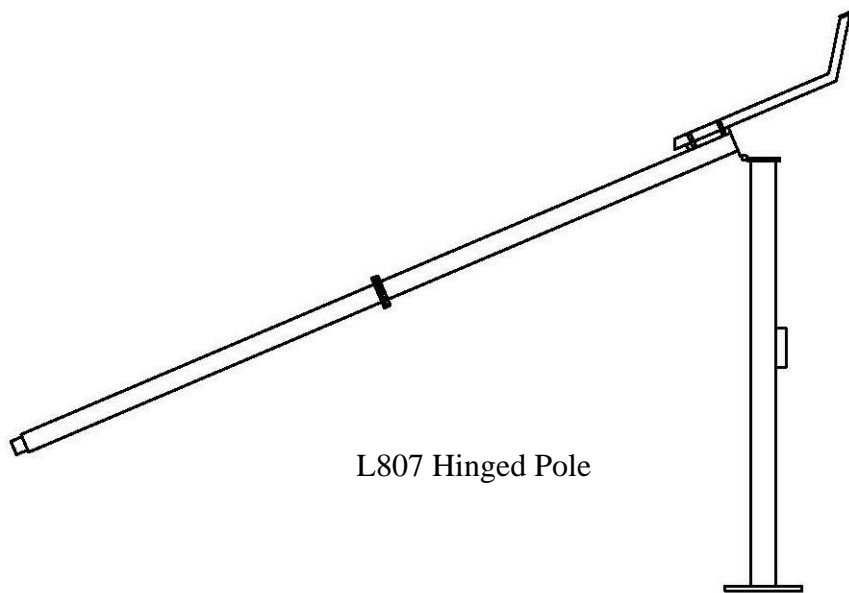
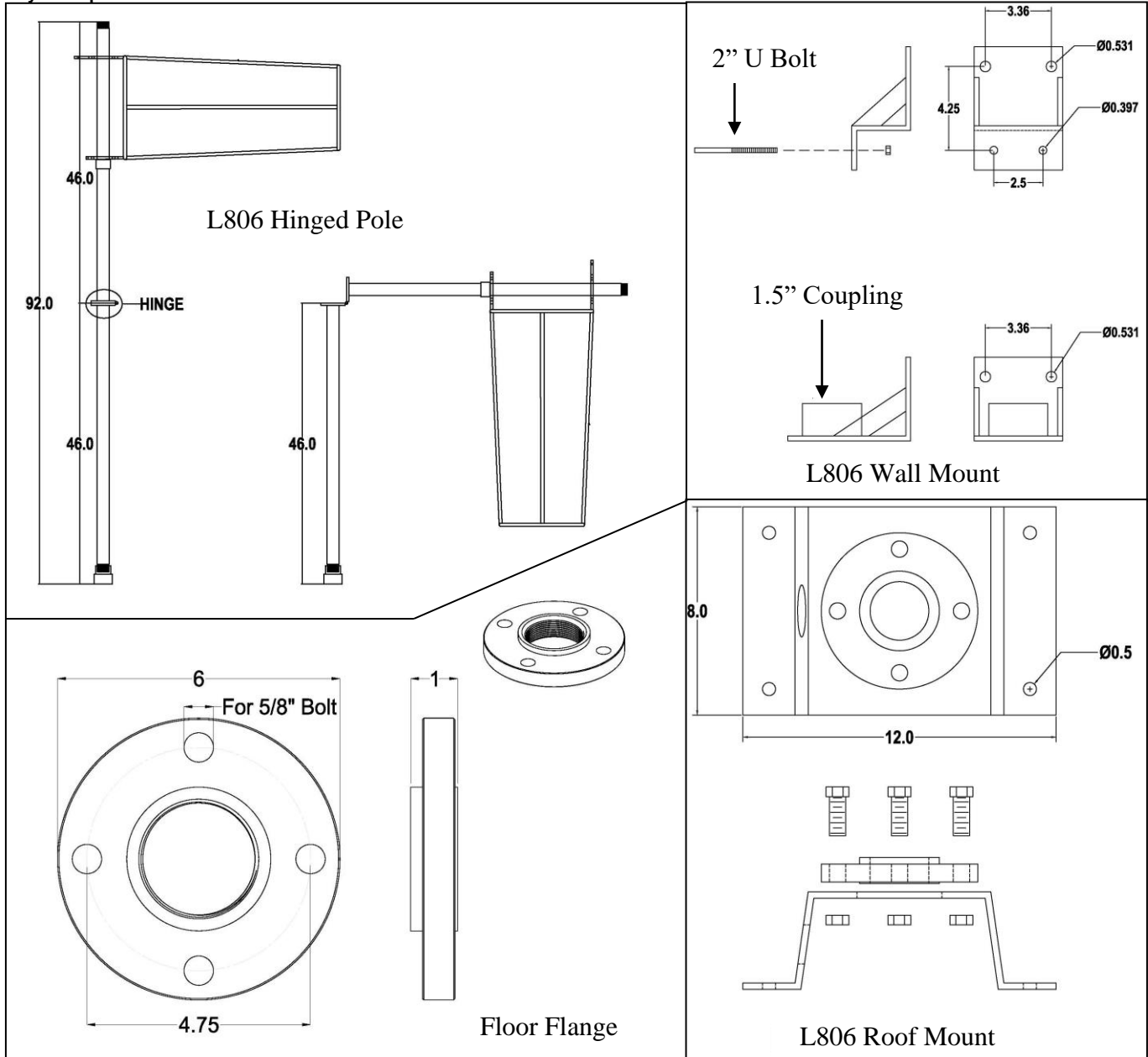

Figure 1. L807 Dimensions



Figure 2. L806 Dimensions

Physical Specifications



CHAPTER 4

Getting Started

Shipping and Unpacking

All components needed for assembly and installation of the L-807, L-807(L), L-806 and L-806(L) are shipped on a standard 10 ft pallet. If additional components or more than one unit is ordered the shipping pallet may be larger. All components are fastened to the shipping pallet, tools will be needed to unfasten these components prior to installation.

After unfastening all the components from the pallet inspect them for damage. If you find components that have been damage from shipping please report them to the shipping company and file a claim.

NOTE: You may want to photograph the damaged components in place on the shipping pallet. This will help you in placing a claim with the shipping company.



CAUTION: Some components are very heavy. Always use correct lifting practices when removing these components from the shipping pallet. If components are too heavy find additional help in removing these components.

If excessive damage has occurred, not allowing assembly of the wind cone, contact Hali-Brite® for replacement parts.

Taking Inventory

Inventory all components prior to installation. Verify that you have everything required to assemble and install the L-807 or L-806 Wind Cone. If there are any missing components contact Hali-Brite®.

⚠ CAUTION: Always take care in handling individual components to prevent damage or injury.

The following components are standard or optional components shipped with an L-807 wind cone.

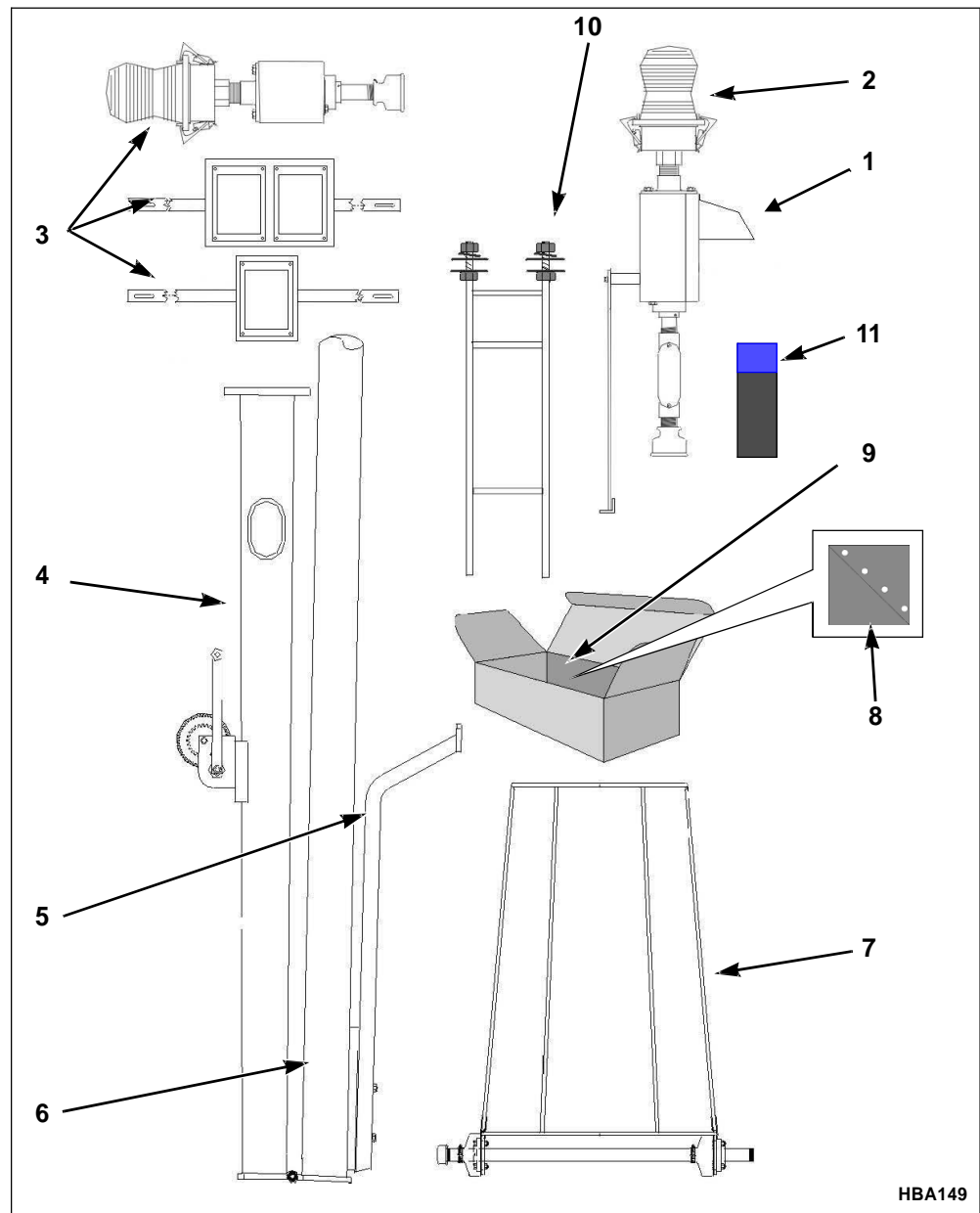

Figure 3. L-807 Wind Cone Components

1.	Exterior Floodlights (optional)	8.	Wind Sock
2.	Obstruction Light	9.	Cable Straps (placed in box)
3.	Interior Floodlight Kit (optional)	10.	Anchor Bar with: 3/4" Lock Washers (4) 3/4" Flat Washers (8) 3/4" Nuts (8)
4.	Pole (bottom half)		
5.	Swing Arm		
6.	Pole (top half)		
7.	18" or 36" Basket	11.	Touch-Up Paint

The following components are standard or optional components shipped with an L-806 wind cone.

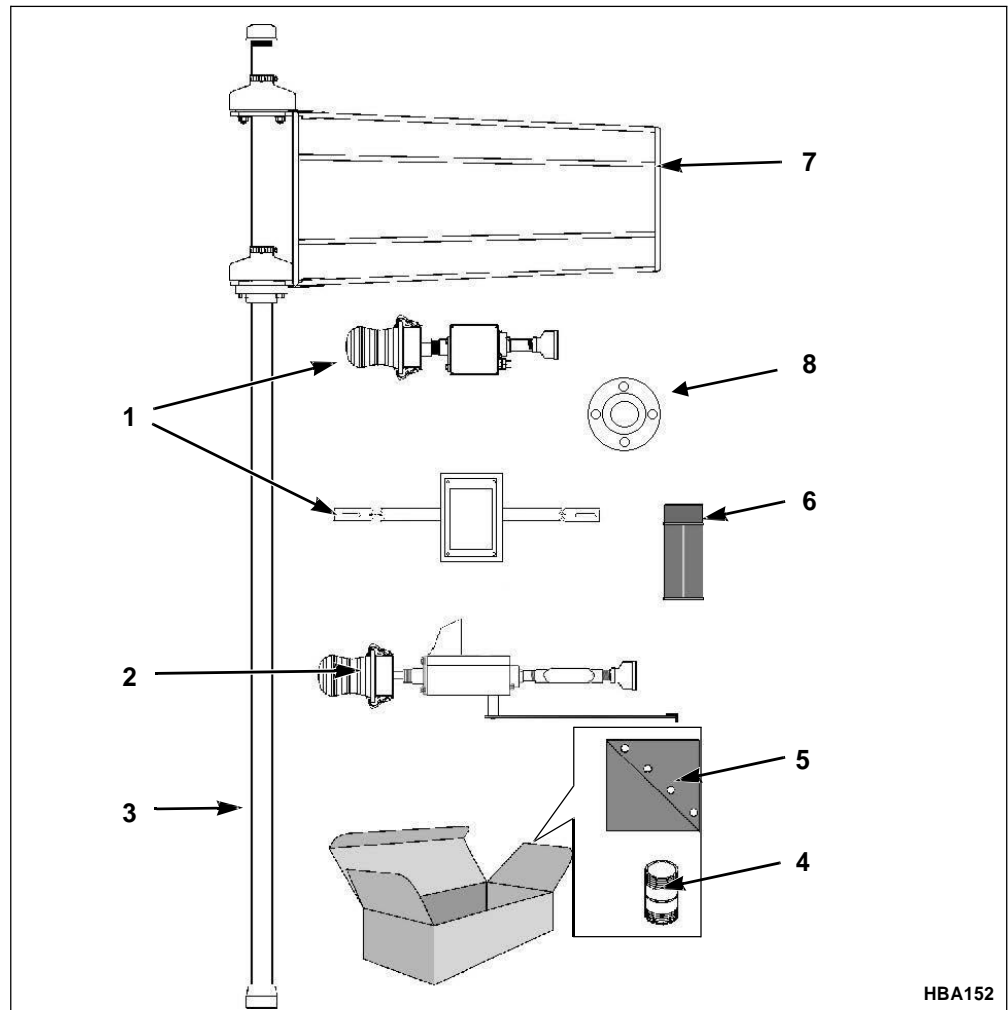

Figure 4. L-806 Wind Cone Components

1.	Interior Floodlight Kit consisting of: * Light pole assembly w/obstruction light * 2-light configuration (optional)	5.	Wind Sock
2.	Exterior Floodlights (optional)	6.	Touch-Up Paint
3.	Pole	7.	18" Basket
4.	Frangible Coupling	8.	Floor Flange

Tools and Supplies Needed

After all components on the shipping pallet have been inventoried you will need to accumulate the following tools. These tools are required for assembling the L-807 or L-806 wind cone.

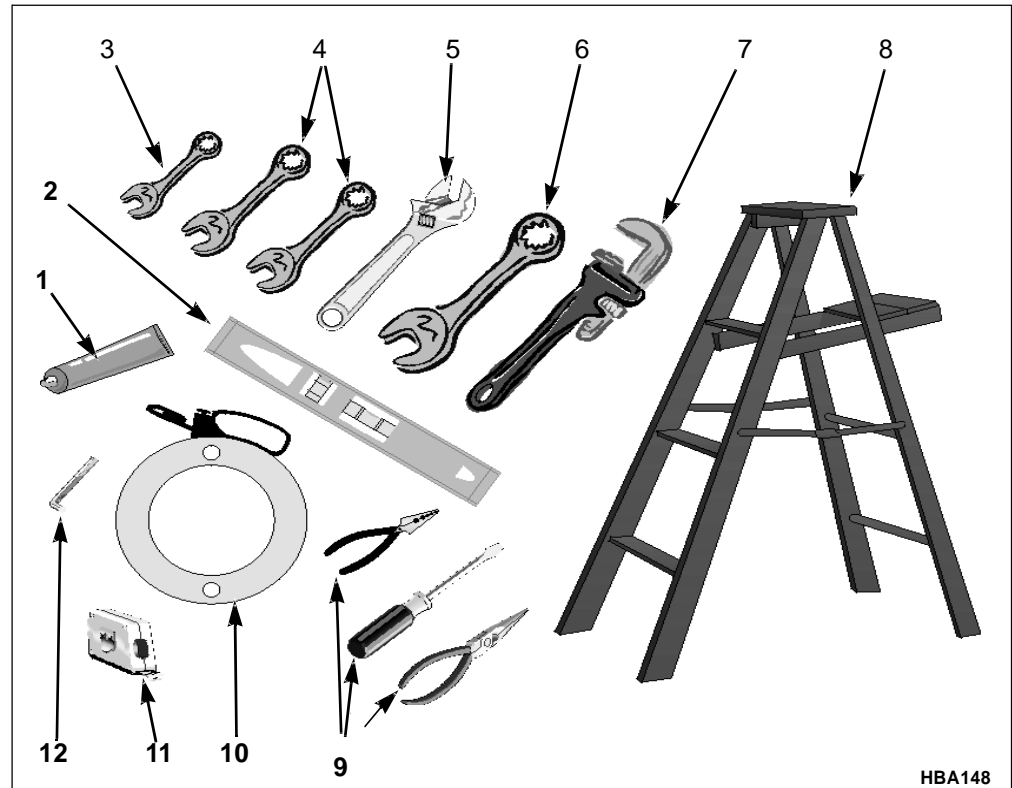

Figure 5. Required Tools

1.	Anti-Locking Compound (Used to prevent threaded components from seizing)	7.	18" Pipe Wrench (Used to secure external light kit to the pole)
2.	12" or larger Carpenter Level (Used to level the anchor)	8.	6 ft Ladder (Used to access hinge on pole)
3.	9/16" Open End Wrench (Used to install the swing arm bolts)	9.	Electrician Tools (Used to wire lighting kit to power source)
4.	Two 5/8" Open End Wrenches (Used to secure the hinge bolts)	10.	50 ft Fishtape (Used to route lighting cable to base of pole)
5.	Large Crescent Wrench (Used to tighten nuts to the anchor bracket)	11.	Tape Measure (Used to set anchor height)
6.	1-1/16" Open End Wrench (Used to level the anchor nuts)	12.	3/16" Allen Hex Wrench (to remove electrical access cover plate)

CHAPTER 5

Installing the L-807 Wind Cone

In order to simplify the installation of the L-807 wind cone, the process can be broken down into the following subtasks. Perform them in the order they are listed below.

1. “Installing the L-807 Wind Cone Anchor” on page 20
2. “Positioning the Swing Arm” on page 23
3. “Placing the Base of the Pole onto the Anchor” on page 24
4. “Attaching the Basket to the Pole” on page 26
5. “Installing Lights” on page 27
6. “Wiring the Lights to the Power Source” on page 30
7. “Installing the Wind Sock to the Basket” on page 31
8. “Raising the Top Half of the Pole” on page 31

Installing the L-807 Wind Cone Anchor

The installation process begins with creating a firm base to which the pole assembly will be mounted. The installation contractor is responsible for the design of the base according to local codes and conditions. The following procedure is only provided as a general guideline for installing the anchor. You may have to modify this procedure to accommodate your location and conditions.

To install the anchor, perform the following steps.

1. Remove the anchor from the shipping pallet.
2. Remove the nuts and washers from each of the anchor's four threaded corner posts.
3. Acquire four 1/2" x 5 ft pieces of rebar.

NOTE: Rebar is not supplied by Hali-Brite®.

4. Use wire to tie each 5 ft piece of rebar to each of the four corner posts, see Item #6 in Figure 7.
5. Dig a hole deep enough to accommodate the anchor and attached rebar legs. The hole should be approximately 7.5 ft deep.
6. Lower the anchor assembly into the hole.
7. Acquire a 1/2" piece of conduit approximately 4 ft long.

NOTE: Conduit is not supplied by Hali-Brite®.

8. Place a 90 degree bend approximately 20" from one end of the conduit, see Item #7 in Figure 7.
9. Place this end of the conduit between the four corner posts and 18" below grade. If possible, wire the conduit in place, see Figure 7.
10. Position the anchor assembly to ensure the anchor threads will protrude 4-5" above the grade of the finished concrete.
11. Fill the hole with concrete. Concrete specifications are to be determined by the installation contractor.
12. Use a carpenter level to level the anchor in all directions, see Figure 6. Check this several times as the concrete is curing.
13. After the concrete has cured, turn a 3/4" nut onto each of the four threaded corner posts. The nut must be turned down as far as it will go.
14. Place a level across two of the 3/4" nuts, see Item #2 in Figure 6. Raise or lower the nuts until they are level, in all directions. This ensures that the post will be level when placed onto the anchor.
15. Place a flat washer on top of each of the four 3/4" nuts, see Figure 6.

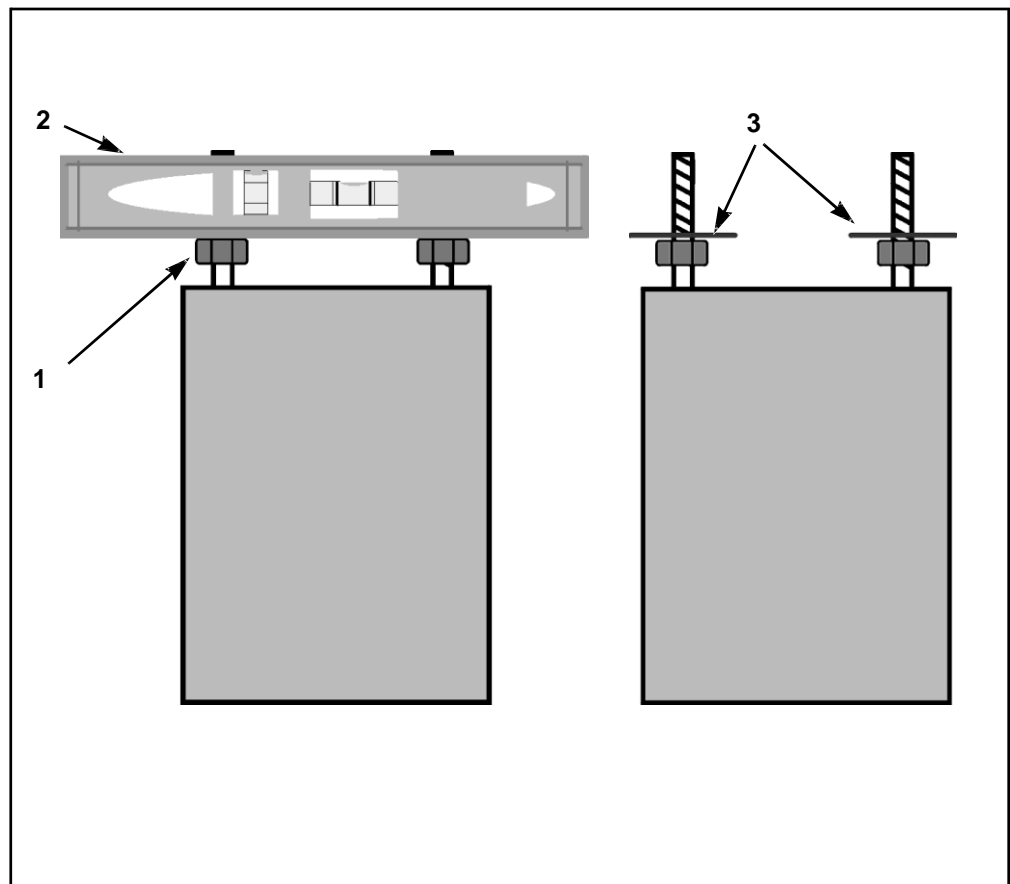
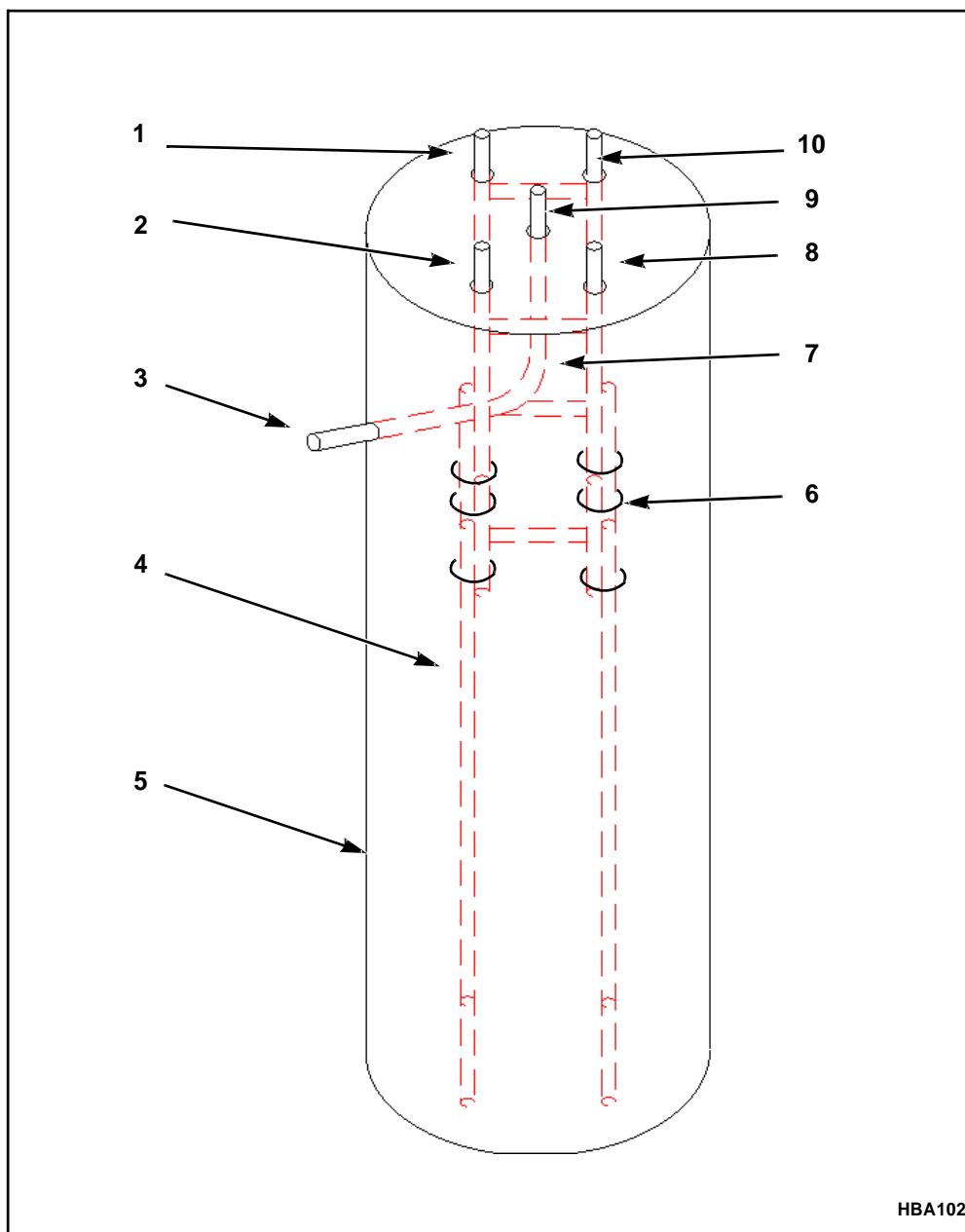

Figure 6. Leveling the Anchor Nuts for the L-807 Wind Cone

1.	3/4" Nut
2.	Carpenter Level
3.	3/4" Flat Washer



HBA102

Figure 7. L-807 Anchor Assembly

1.	Threaded corner post	6.	Wire ties
2.	Threaded corner post	7.	90 Degree bend in conduit
3.	1/2 in. conduit, 18" below grade	8.	Threaded corner post
4.	1/2 in. x 5 ft rebar legs wired to anchor	9.	1/2 inch conduit 2 inches above concrete
5.	Concrete Base 7.5 ft deep	10.	Threaded corner post

Positioning the Swing Arm

After installing the anchor, the swing arm must be correctly positioned. This is done by performing the following steps.

1. Using a 9/16" wrench, remove the bottom swing arm bolt and loosen the top swing arm bolt, see Figure 8.

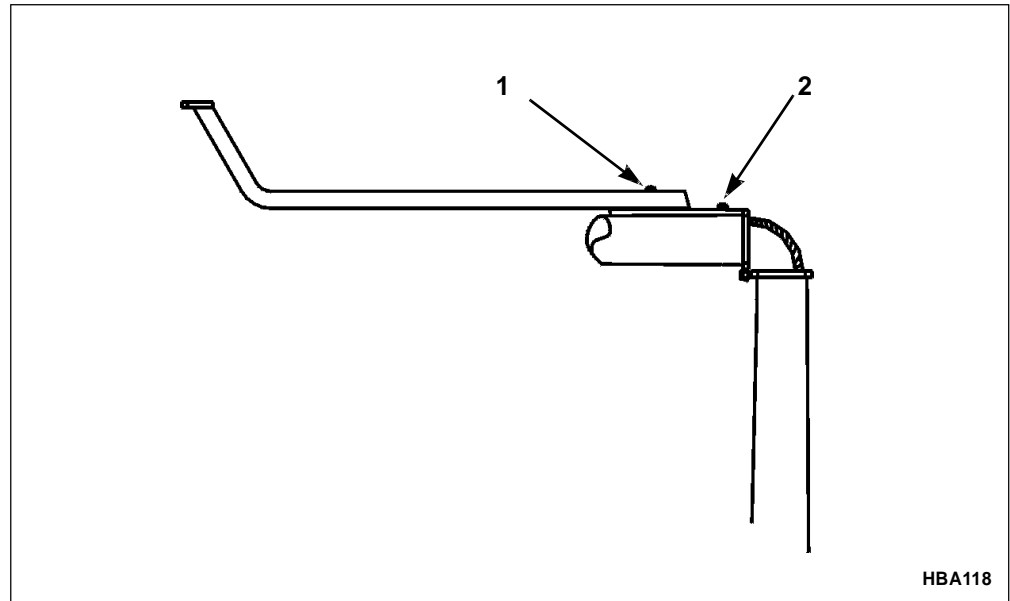

Figure 8. Positioning the Swing Arm

1.	Top Swing Arm Bolt
2.	Bottom Swing Arm Bolt

2. Rotate the swing arm to position as shown in Figure 9.
3. Place the bottom bolt back through the swing arm.
4. Tighten both swing arm bolts.
5. Attaching upper pole section to lower pole, see the following procedure.

Attaching the upper pole section to the lower pole

Attaching the upper pole section to the lower pole is done by performing the following steps.

1. Using a 9/16" wrench, attach the upper pole section to the lower pole with the four 3/8" bolts, eight flat washers, four lock washers and four 3/8" nuts provided, see Figure 8A.

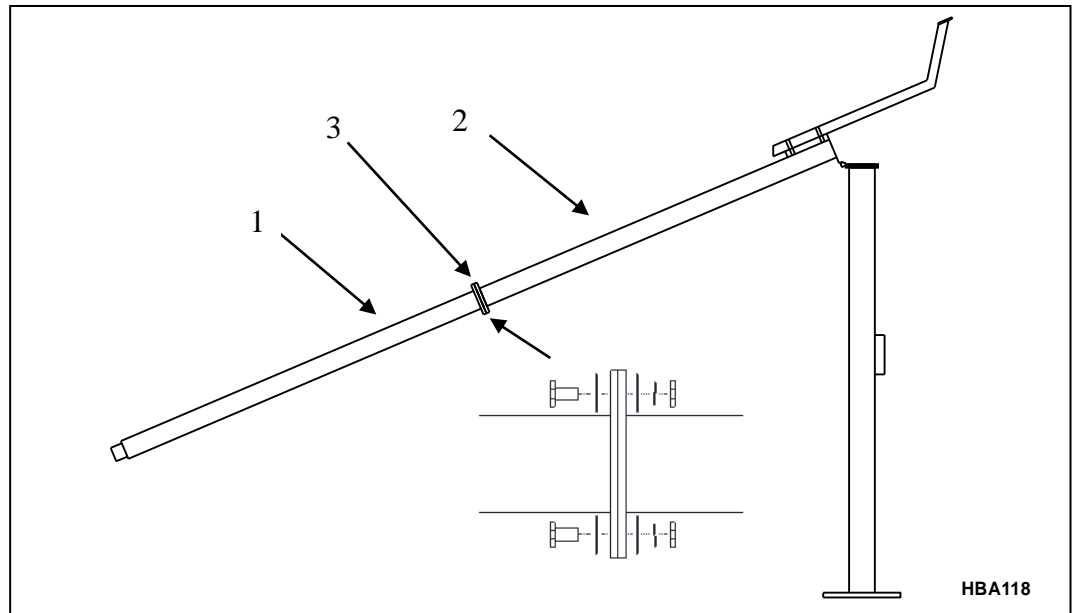

Figure 8A Attaching upper pole to lower pole

1	Top Pole Section
2	Lower pole section
3	Mounting Plates

Placing the Base of the Pole onto the Anchor

After the swing arm has been positioned, attach the pole to the anchor by performing the following steps.

1. Verify that the anchor has a 3/4" nut turned onto each of the anchor's four corner posts and that they have been leveled, see Figure 6. The four bottom nuts are used to level the pole. These nuts must be leveled prior to mounting the pole, see "Installing the L-807 Wind Cone Anchor" on page 20.

2. Verify that a flat washer has been placed on top of each 3/4" nut, see Figure 6.

⚠ CAUTION: *The following step requires two or more individuals. Use proper lifting techniques when raising or lowering heavy components.*

3. Position one person at the top half of the pole and one at the bottom half of the pole.
4. With both people lifting at the same time, lift the base of the pole over the top of the four corner posts, see Figure 9.
5. With the base of the pole on top of the four corner posts, place a 3/4" flat washer on top of each corner post, see Figure 9.
6. Place a 3/4" lock washer on top of each flat washer, see Figure 9.
7. Screw a 3/4" nut onto each corner post and tighten nuts using a 1-5/8" wrench until base of pole is secure, see Figure 9.

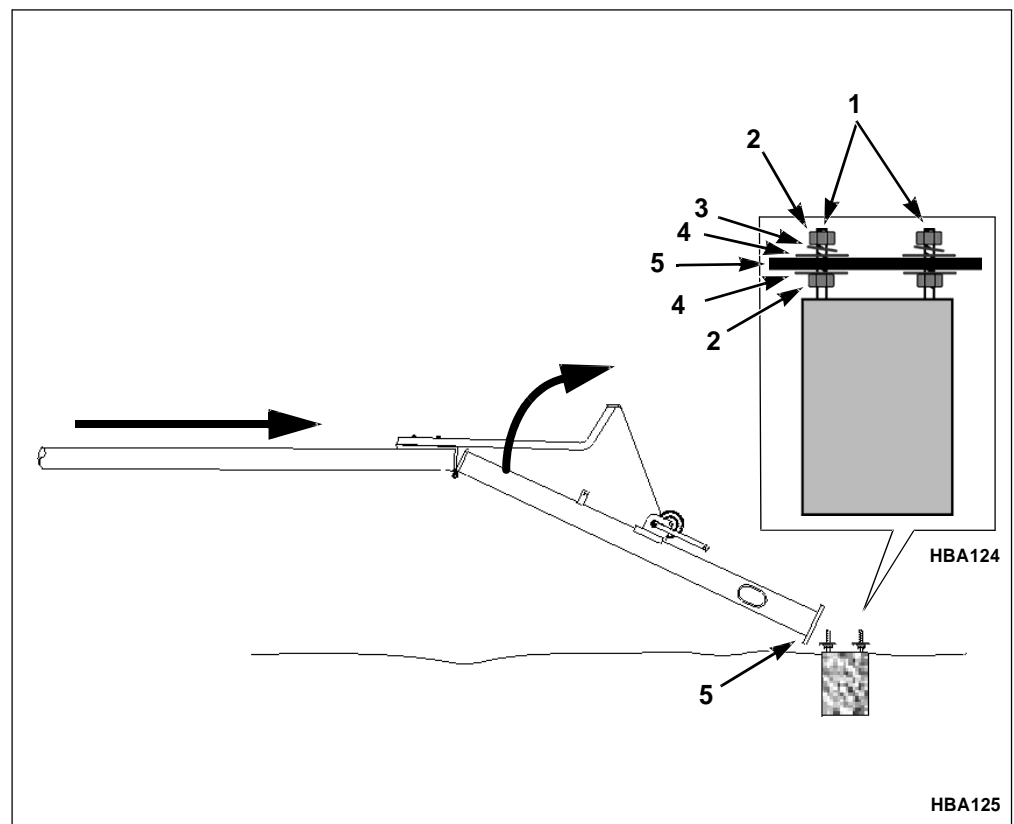

Figure 9. Fastening the Base to the Pole

1.	Threaded Corner Posts (4)	4.	3/4" Flat Washer (8)
2.	3/4" Nut (8)	5.	Base of Pole
3.	3/4" Lock Washer (4)		

8. Crank the top half of the pole to a comfortable working position.
9. Attach the basket to the pole, see the following procedure.

Attaching the Basket to the Pole

After the swing arm has been correctly positioned and the pole has been attached to the anchor, attach the basket to the pole.

1. Remove the basket from the shipping pallet.
2. Rotate the basket so the rain caps are pointed away from the pole, see Figure 10.

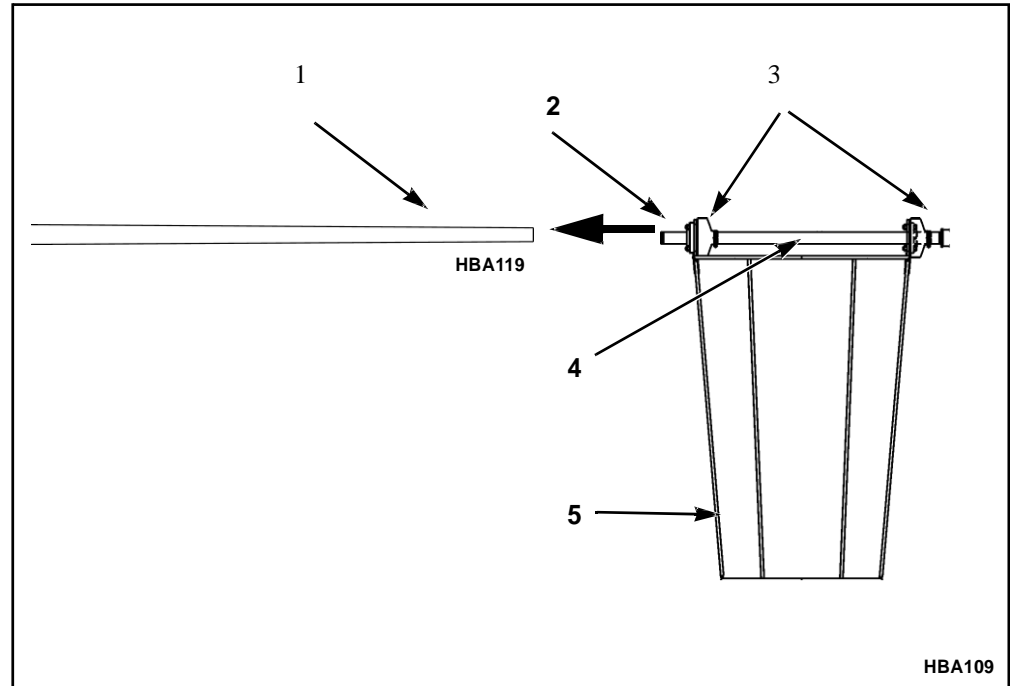

Figure 10. Positioning the Basket

1.	Top End of Pole
2.	Anti-locking Compound to Threads
3.	Rain Caps
4.	Basket Support Pipe
5.	Correctly Positioned Basket

3. Apply anti-locking compound to the threads of basket support pipe, see Figure 10.
4. Screw the basket to the top of the pole.
This is done by placing an 18" pipe wrench or larger around the basket support pipe. Tighten until secure and at least 2/3 of the threads are engaged.
5. Inspect the entire assembly for nicks or other damage to painted surfaces. Apply the supplied paint to these areas.
6. Attach the lights to the basket, see the following procedure "Installing Lights" on the following page. If the wind cone is unlighted, proceed to "Installing the Wind Sock to the Basket" on page 31.

Installing Lights

Perform one of the following:

- a. If external lights are required: continue with “Installing the External Lighting Kit” below.
- b. If internal lights are required: continue with “Installing the Internal Lighting Kit” on page 29.

Installing the External Lighting Kit

After the basket has been attached to the pole, you can install the external lighting kit. See Figure 12 for details.

1. Remove the access hole cover at the base of the pole, see Figure 12.
2. Push a fish tape into the access hole and up to the hinge at center of pole.
3. Insert the fish tape through the eyebolt welded to the inside of the upper pole.
4. Push the fish tape wire through the eyebolt and then through the top half of the pole.
5. Remove the end of the fish tape from the top of the pole.
6. Remove the lighting kit from the pallet and place it on the ground near the top of the basket.
7. Remove cable straps, used for shipping, from the electrical cable.
8. Attach the ends of the wire cable to the end of the fish tape.

NOTE: This requires that you wrap the ends of the wire and fish tape with black electrical tape to prevent the wires from coming loose when pulling the cable down to the access hole.

9. Using the fish tape, pull the wire cable through the top of the pole, then the eyebolt, then the bottom of the pole and finally out the access hole, see Figure 12.
10. Disconnect the wire from the fish tape. Pull all excess cable out of the access hole.
11. Place anti-locking compound onto the threads at the top of the basket support pipe. Make sure all threads have been covered thoroughly.
12. Mount the lighting kit onto the basket support pipe using a pipe wrench.
13. Refer to Figure 11. Remove the bolt, flat washer and lock washer from the upper bracket attachment. Remove the nut, flat washer and lock washer from the lower bracket attachment. Place the light support bracket on the upper and lower bracket attachment points as shown in Figure 11, with the slotted end of the light support bracket towards the wind cone lamp. Reinstall the upper bracket bolt and washers and the lower bracket nut and washer, but only finger-tight.

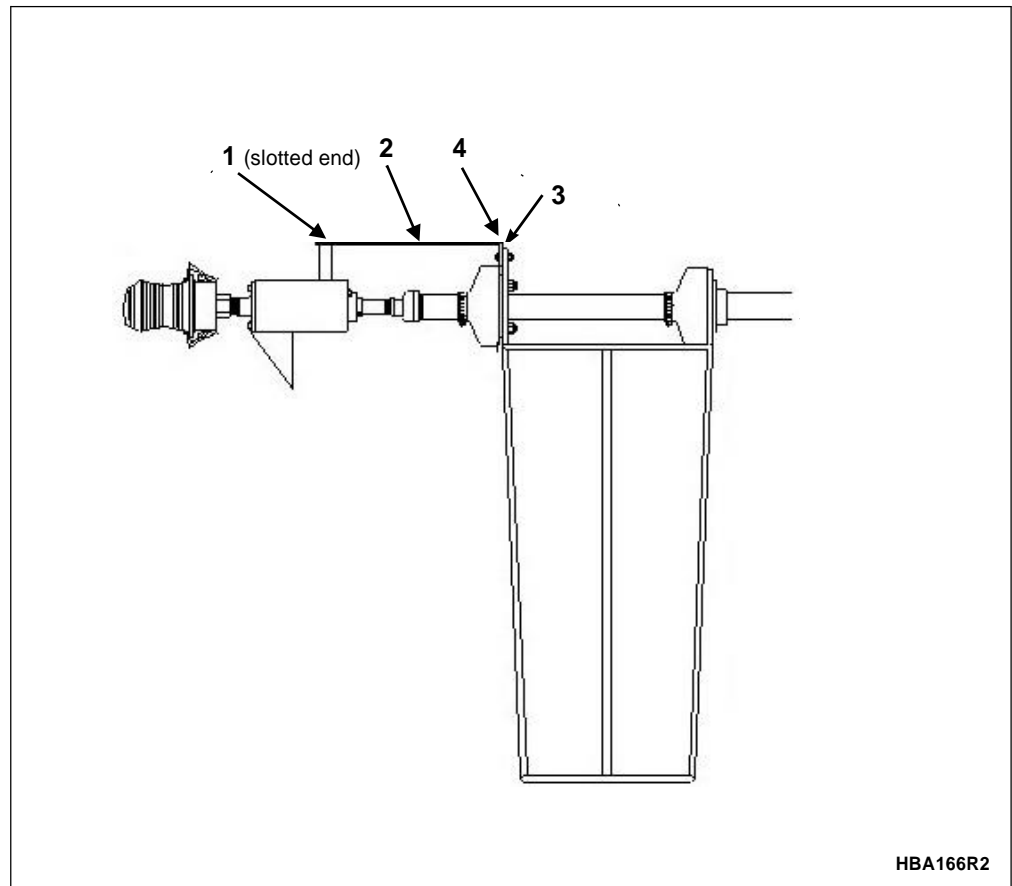
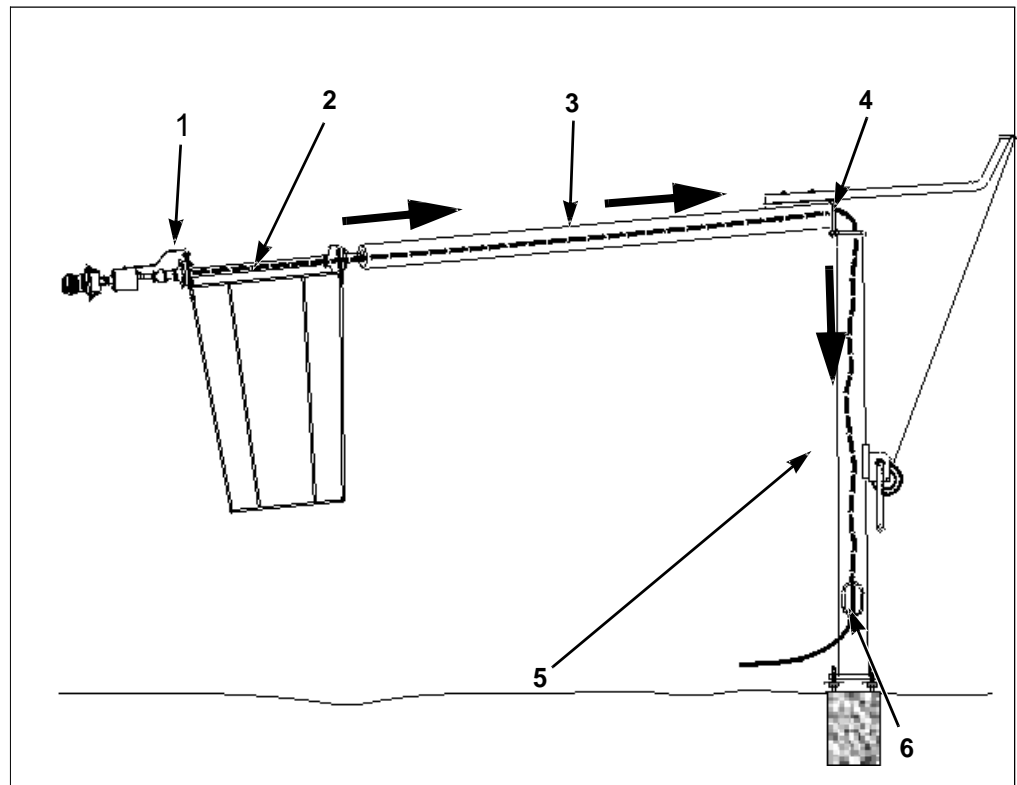

Figure 11. Installing the External Lighting Kit

1.	Upper Bracket Attachment
2.	Light Support Bracket
3.	Basket Bracket
4.	Lower Bracket Attachment

14. Tighten the fasteners on both ends of the light support bracket, see Figure 11.
15. Crank the top of the pole to its lowest position.
16. Wire and test the lights, see “Wiring the Lights to the Power Source” on page 30.
17. Install the wind sock, see “Installing the Wind Sock to the Basket” on page 31.



HBA163

Figure 12. Feeding the Electrical Cable

1.	Feed end of cable into top of basket support pipe
2.	Pull cable through basket support pipe
3.	Pull cable through top half of pole
4.	Pull cable through eyebolt
5.	Pull cable down through bottom half of pole
6.	Pull cable out access hole

Installing the Internal Lighting Kit

After the basket has been attached to the pole, install the internal lighting kit. This is done by performing the following steps.

1. Remove the internal lighting kit components from the shipping pallet.
2. Remove the two U-bolts from the lightbar, see Figure 13.
3. **NOTE: Place the lightbar across the center of the large end of the basket, see Figure 13. The floodlights must point into the basket. Position the bar horizontally, (parallel to the ground).**
4. Place the two U-bolts around the basket frame and back through the holes in the lightbar, see Figure 13.
5. Tighten the U-bolts to the basket frame.
6. Place anti-locking compound on the basket support pole threads.

7. Tighten the lighting kit to the basket support pipe. Tighten until secure and at least 2/3 of the threads are engaged
8. Wire and test the lights, see “Wiring the Lights to the Power Source” on page 30.

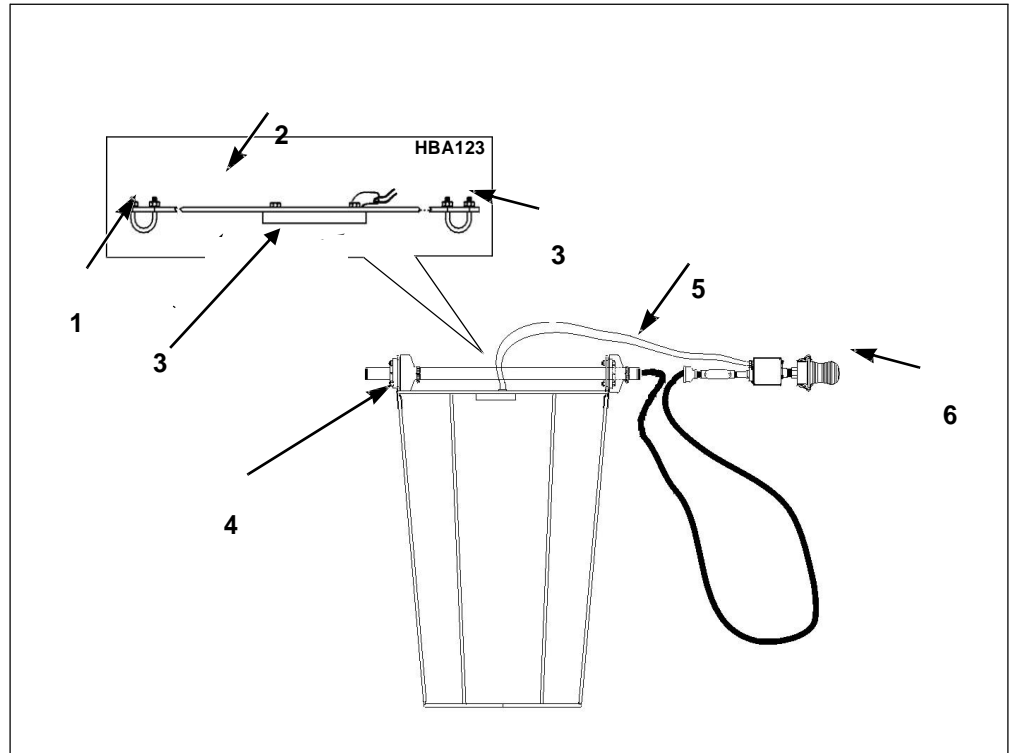

HBA122

Figure 13. Installing the Internal Lighting Kit

1.	U-Bolts
2.	Lightbar
3.	Internal Lamp Assembly
4.	Basket Frame
5.	Apply Anti-locking Compound
6.	Obstruction Light

Wiring the Lights to the Power Source

After the electrical cable has been pulled through the pole you can wire the lights to the power source and test them. See “Wiring Diagrams” on page 44.

NOTE: *Attach a suitable earth ground to the grounding lug located inside the pole access cover.*

If all lights illuminate and appear to be in working order you can then install the wind sock, see “Installing the Wind Sock to the Basket” on page 31.

Installing the Wind Sock to the Basket

After the basket has been attached to the top of the pole and any optional lighting kits installed, you can install the wind sock by performing the following steps.

1. Remove the wind sock from the shipping pallet.
2. One end of the sock has eyelets, open this end and slide the sock over the small end of the basket, see Figure 14.
3. Slide the sock over the basket until the entire basket is covered, see Figure 14.
4. Locate the group of cable straps on the shipping pallet.
5. Place a cable strap through each eyelet and around the basket frame.
6. Tighten each cable strap and clip off any excess portion of each cable strap.

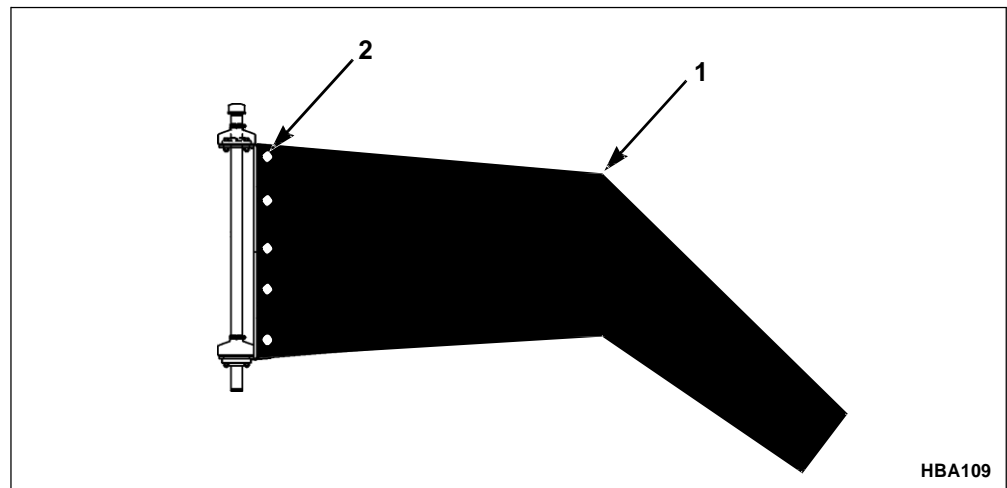

Figure 14. Installing the Wind Sock

1.	Wind Sock
2.	Eyelets

7. Raise the top half of the pole, see the following procedure.

Raising the Top Half of the Pole

After the wind sock has been installed, raise the top half of the pole into position.



CAUTION: Disconnect power going to the lights before raising the pole.

1. Using the hand crank on the winch, raise the pole until the hinge is closed, see Figure 15.

2. Place a bolt into each of the four holes in the hinge located at the center of the pole, see Figure 15.
3. Secure the four bolts and nuts.

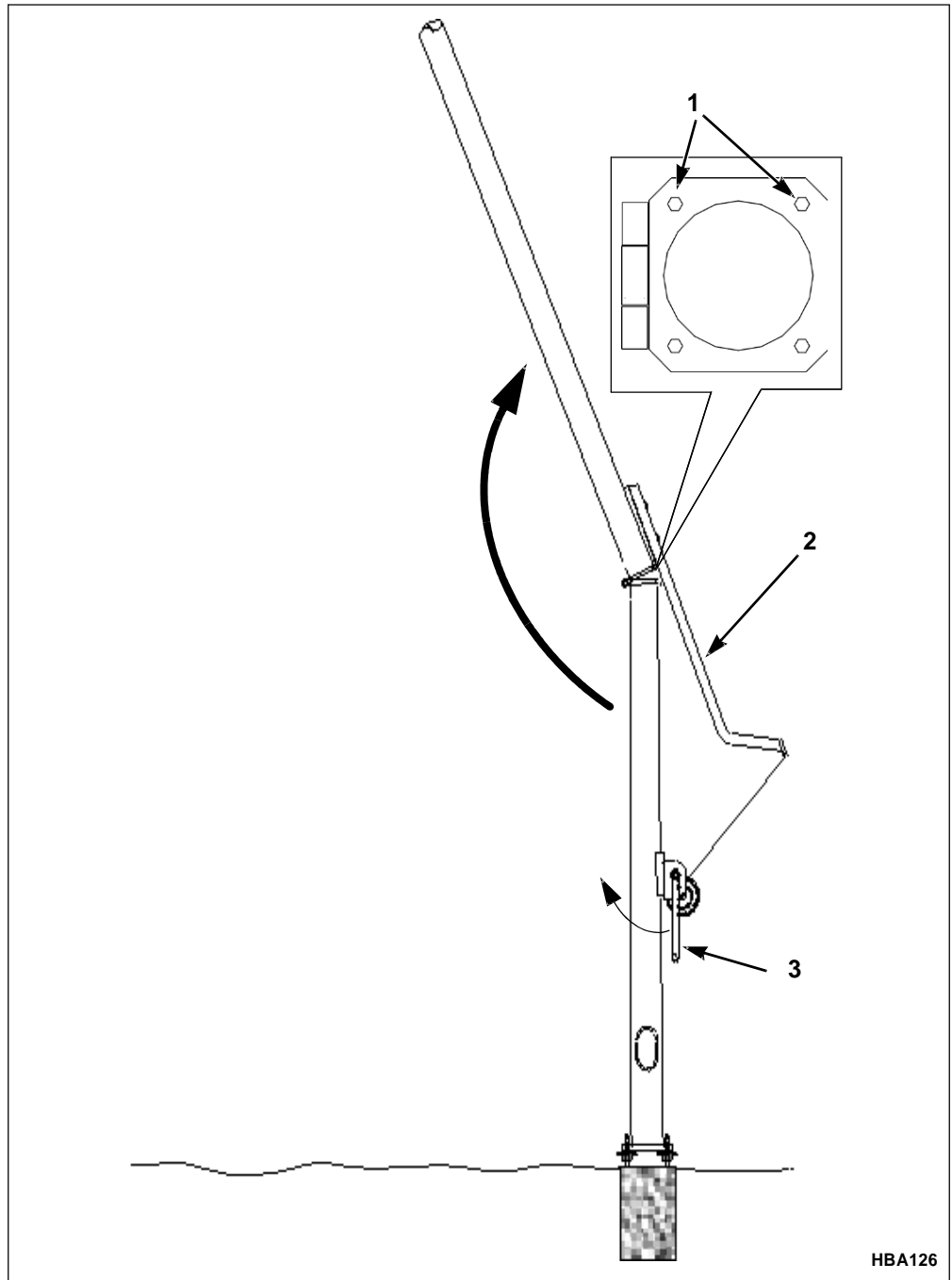

Figure 15. Raising the Top Half of the Pole

1.	7/16" Hinge Bolts (4)
2.	Swing Arm
3.	Winch Handle

CHAPTER 6

Installing the L-806 Wind Cone

In order to simplify the installation of the L-806 wind cone the process can be broken down into the following subtasks. Perform them in the order they are listed below.

1. “Installing Lights” on page 33
2. “Installing the Wind Sock to the Basket” on page 36
3. “Assembling the Pole to the Baseplate” on page 37
4. “Wiring the Lights to the Power Source” on page 37
5. “Attach the Pole Assembly to the Base Can” on page 38

Installing Lights

Perform one of the following:

- a. If no lights are required: continue with “Installing the Wind Sock to the Basket” on page 36.
- b. If external lights are required: continue with “Installing the External Lighting Kit” on page 34.
- c. If internal lights are required: continue with “Installing the Internal Lighting Kit” on page 35.

Installing the External Lighting Kit

Install the external lighting kit by performing the following steps.

1. Remove the external lighting kit from the pallet and place it on the ground near the top of the basket.
2. Remove cable straps, used for shipping, from the electrical cable.
3. Push the wire cable through the basket support pipe, down through the pole, and out the bottom, see Figure 16.
4. Place anti-locking compound onto the threads at the top of the basket support pipe, see Figure 16. Tighten until secure and at least 2/3 of the threads are engaged.
5. Tighten the lighting kit onto the basket support pipe.
6. Refer to Figure 11. Remove the bolt, flat washer and lock washer from the upper bracket attachment. Remove the nut, flat washer and lock washer from the lower bracket attachment. Place the light support bracket on the upper and lower bracket attachment points as shown in Figure 11, with the slotted end of the light support bracket towards the wind cone lamp. Reinstall the upper bracket bolt and washers and the lower bracket nut and washer, but only finger-tight.
7. Tighten the fasteners on both ends of the light support bracket, see Figure 11.
8. Install the wind sock, see “Installing the Wind Sock to the Basket” on page 36.

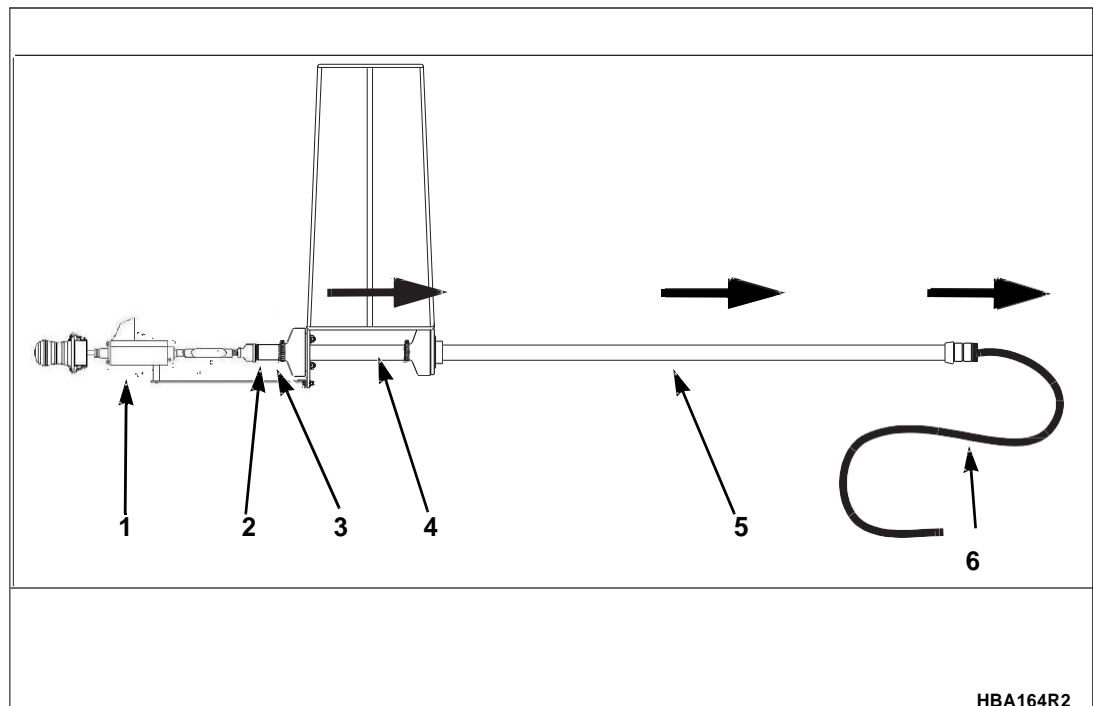

Figure 16. Feeding the Electrical Cable

1.	Place lights on ground
2.	Feed end of cable into top of basket support pipe
3.	Place anti-locking compound on threads
4.	Pull cable through basket support pipe
5.	Pull cable through pole
6.	Pull excess cable out bottom of pole

Installing the Internal Lighting Kit

Install the internal lighting kit by performing the following steps.

1. Remove the internal lighting kit from the shipping pallet.
2. Remove the two U-bolts from the light bar, see Figure 17.
3. **NOTE: Place the lightbar across the center of the large end of the basket, see Figure 17. The floodlights must point into the basket. Position the bar horizontally (parallel to the ground).**
4. Place the two U-bolts around the basket frame and back through the holes in the light bar, see Figure 17.
5. Tighten the U-bolts to the basket frame, see Figure 17.
6. Place anti-locking compound on the basket support pipe threads.
7. Screw the lighting kit to the basket support pipe. Tighten until secure and at least 2/3 of the threads are engaged
8. Install the wind sock, see “Installing the Wind Sock to the Basket” on page 36.

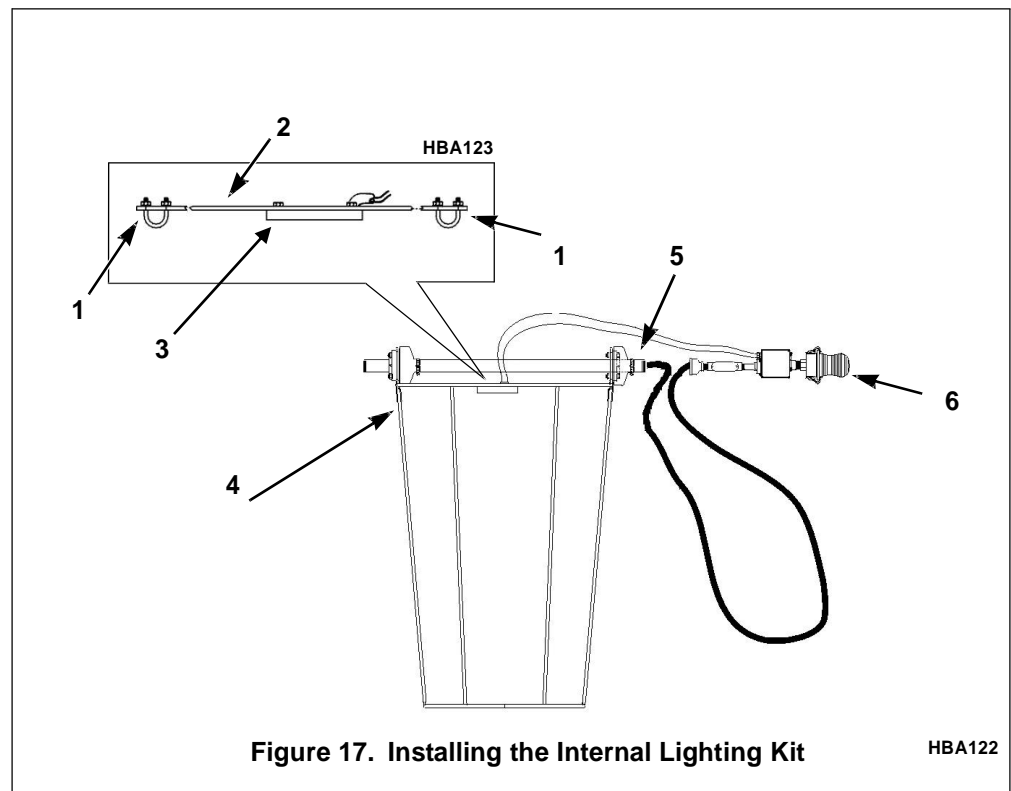

Figure 17. Installing the Internal Lighting Kit

HBA122

1.	U-Bolts
2.	18" Light Bar
3.	Internal Lamp Assembly
4.	Basket Frame
5.	Apply Anti-locking Compound
6.	Obstruction Light

Installing the Wind Sock to the Basket

After the basket has been attached to the top of the pole and any lighting kit installed, you can install the wind sock by performing the following steps.

1. Remove the wind sock from the shipping pallet.
2. One end of the sock has eyelets, open this end and slide the sock over the small end of the basket, see Figure 18.
3. Slide the sock over the basket until the entire basket is covered, see Figure 18.
4. Remove the group of cable straps from the shipping pallet.
5. Place a cable strap through each eyelet and around the basket frame.
6. Tighten each cable strap and clip off any excess portion of each cable strap.

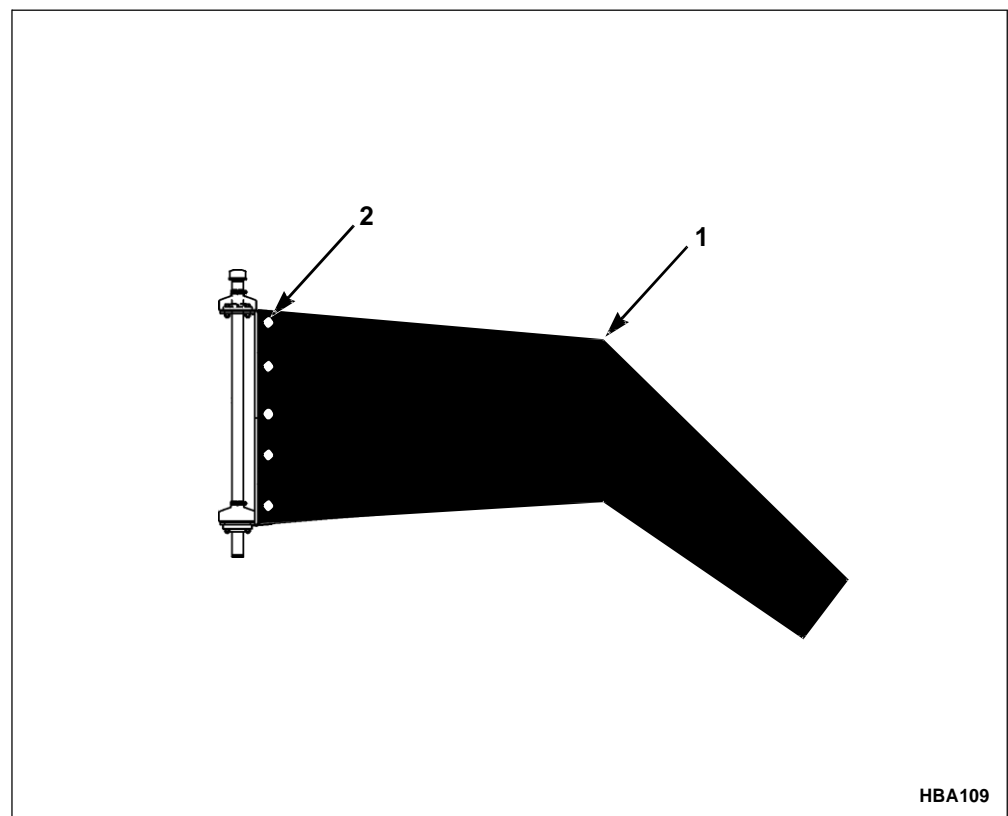

Figure 18. Installing the Wind Sock

1.	Wind Sock
2.	Eyelets

7. Inspect the entire assembly for nicks or other damage to painted surfaces. Apply the supplied paint to these areas.
8. Assemble the pole to the baseplate, see “Assembling the Pole to the Baseplate” on page 37.

Assembling the Pole to the Baseplate

Before the pole assembly can be erected you need to attach the pole and basket to the baseplate. This can be done by performing the following steps.

1. Remove the frangible coupling from the shipping pallet and screw it into the baseplate, see Figure 19.
2. Screw the pole assembly to the frangible coupling.
3. Wire the lights to the power source, see the following procedure.

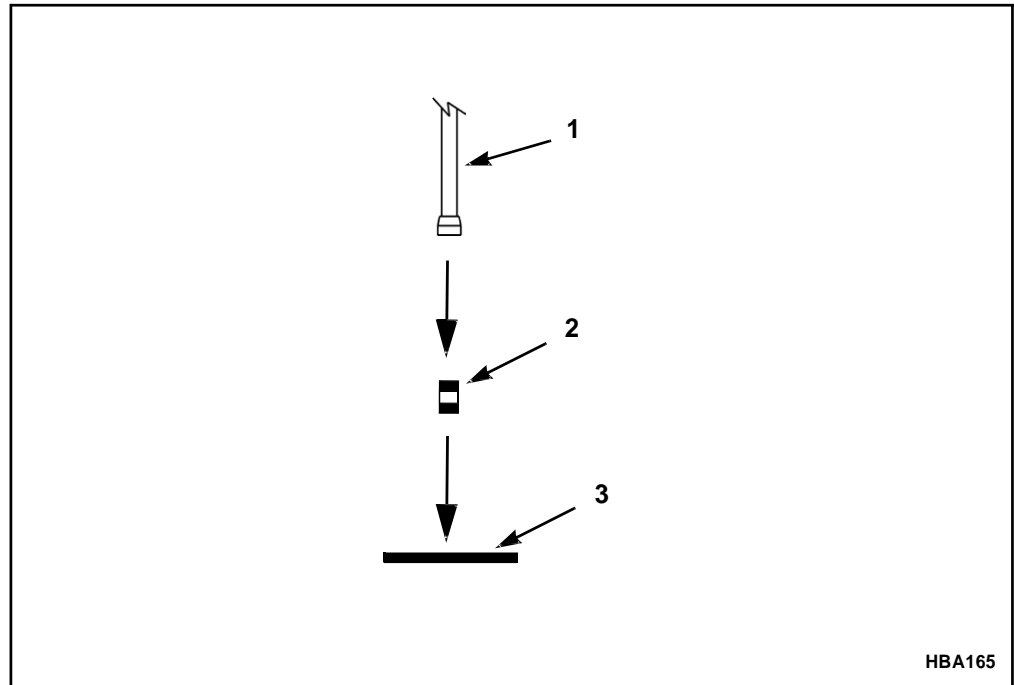

HBA165

Figure 19. Attaching the Pole

1.	Pole
2.	Frangible Coupling
3.	Baseplate

Wiring the Lights to the Power Source

After the pole has been assembled to the baseplate, wire the lights to the power source and test them. See “Wiring Diagrams” on page 44.

If all lights illuminate and appear to be in working order you can then attach the pole to the base can, see the following procedure.

Attach the Pole Assembly to the Base Can

To attach the completed pole assembly to the base can grasp the pole assembly near the bottom of the basket and stand the pole assembly upright. Move the baseplate on top of the base can and bolt in place.

CHAPTER 7

Maintaining and Servicing the Wind Cones

NOTE: Always perform maintenance based on frequency as established by airport policies and procedures and by FAA Advisory Circular AC 150/5340-26.

Tools Required

Tools needed to service the L-807 and L-806 Wind Cones are listed in “Tools and Supplies Needed” on page 18.

Lowering the Top of the L-807 Pole

To perform maintenance on the top half of the L-807 pole you must lower it nearer to the ground. This is done by performing the following steps.

1. Remove the four hinge bolts from the hinge at the center of the pole, see Figure 20 on page 40.
2. Using the winch slowly crank the pole down. Lower the pole to an easy working height, see Figure 20 on page 40.



CAUTION: *Do not support the pole on the basket. Use a sawhorse, or other suitable support.*

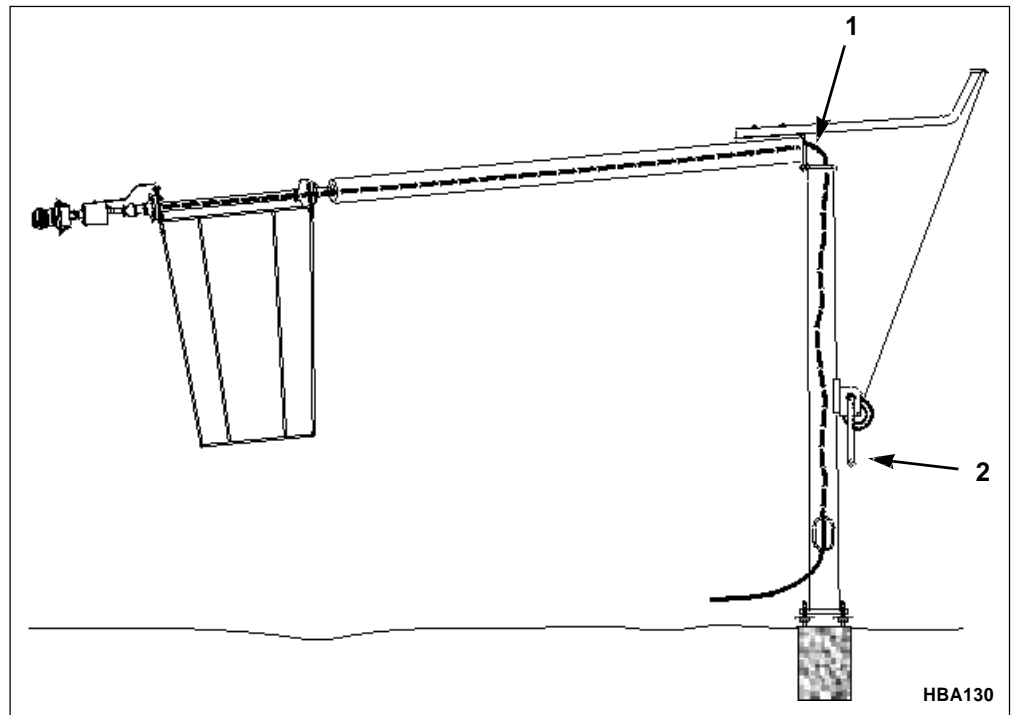

Figure 20. Lowering the Basket

1.	Hinge bolts (4)
2.	Winch handle

Inspecting Wind Cone Components

The following tables list the inspections that must be performed on a regular basis.

TABLE 2. Daily Maintenance Recommendations

Component	Action
Check lamps for operation.	Replace faulty lamps. Always clean globes inside and outside when replacing lamps.

TABLE 3. Monthly Maintenance Recommendations

Component	Action
Check wind sock for frayed edges.	Replace if torn.
Check pole for cracks.	Replace cracked pole.
Check structure for bird nests or insect problems.	Remove from structure.
Check for paint damage.	Apply touch-up paint as required.
Check wind sock for missing cable straps.	Replace missing or worn cable straps.

TABLE 3. Monthly Maintenance Recommendations (Continued)

Component	Action
Check lights for dirty lenses.	Clean with a soft damp cloth.
Check base of pole for excessive vegetation growth.	Remove vegetation.
Check winch cable for fraying or corrosion (L-807 Only).	Replace if needed.

TABLE 4. Semi-Annual Maintenance Recommendations

Component	Action
Check wiring for cracked insulation.	Call a qualified electrician, repair as necessary.
Check wind sock for missing eyelets.	Replace sock.
Check wind sock for fading.	Replace sock.
Make an insulation reading and compare results with standards and previous readings.	Replace if needed.
Check winch for proper operation.	Replace if inoperative.
Check bearing lubrication	Lubricate basket bearings

Replacing Lamps

All models with LED lamps have a rated lamp life of 50,000 hours. All LED lamps are repaired by replacing the entire housing assembly. Contact Hali-Brite® for LED lamp replacements.

Description	Part Number
Lamp, 6.6Amp Internal Size 2 LED	9200-0031
Lamp, 120V External Size 1 LED	9200-0032
Lamp, 12VDC External Size 1 LED	9200-0033
Lamp, 6.6Amp External Size 1 LED	9200-0034
Lamp, 120V External Size 2 LED	9200-0035
Lamp, 12VDC External Size 2 LED	9200-0036
Lamp, 6.6Amp External Size 2 LED	9200-0037
Lamp, 120V Internal Size 1 LED	9200-0038
Lamp, 6.6Amp Internal Size 1 LED	9200-0039
Lamp, 120V Internal Size 2 LED	9200-0040
Lamp, 12VDC Internal Size 1 LED	9200-0041
Lamp, 12VDC Internal Size 2 LED	9200-0042
Lamp, 230/240V External Size 2 LED	9200-0043
Lamp, 230/240V External Size 1 LED	9200-0044
Lamp, 230/240V Internal Size 1 LED	9200-0045
Lamp, 230/240V Internal Size 2 LED	9200-0046

Replacing an Obstruction Light

1. Disconnect power to wind cone.
2. Release the two clasps that attach the light to the housing.
3. Remove wire nuts connecting the old obstruction light and remove light.
4. Reverse steps to install new obstruction light.

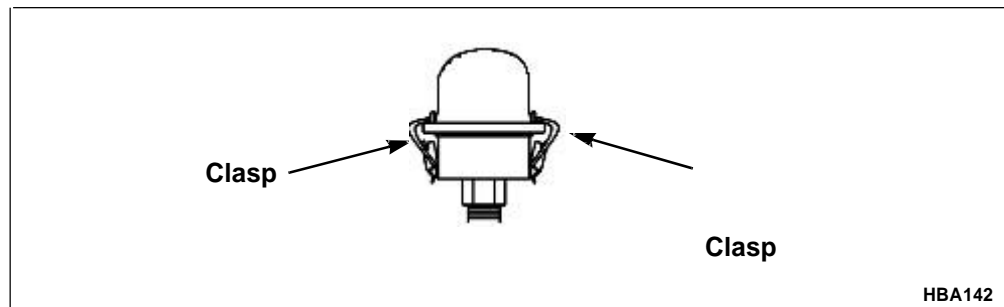
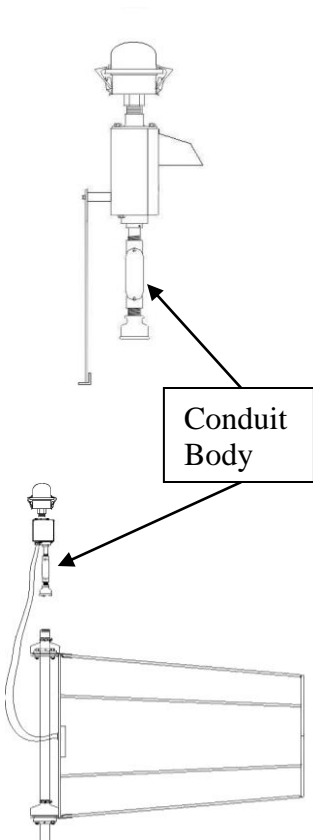

Figure 23. Removing the Obstruction Light

Replacing External Lighting Kit

1. Remove the fasteners on both ends of the light support bracket.
2. Remove wire nuts inside conduit body, remove cable from cable clamp and unscrew lamp from pole just below reducer.
3. Guide cable into conduit body of new lamp and screw onto pole.
4. Tighten the lighting kit onto the basket support pipe.
5. Tighten the fasteners on both ends of the light support bracket.
6. Reinstall cable through clamp in conduit body and replace wire nuts.



Replacing Internal Lighting Kit

1. Remove wire nuts inside conduit body, remove cable from cable clamp and unscrew lamp from pole just below reducer.
2. Remove the two nuts on the back of lamp and remove lamp from mounting bar.
3. Guide cable into conduit body of new lamp and screw onto pole.
4. Reinstall lamp to mounting bar and tighten nuts.
5. Reinstall cable through clamp in conduit body and replace wire nuts.

L806 Replacement Part Diagram

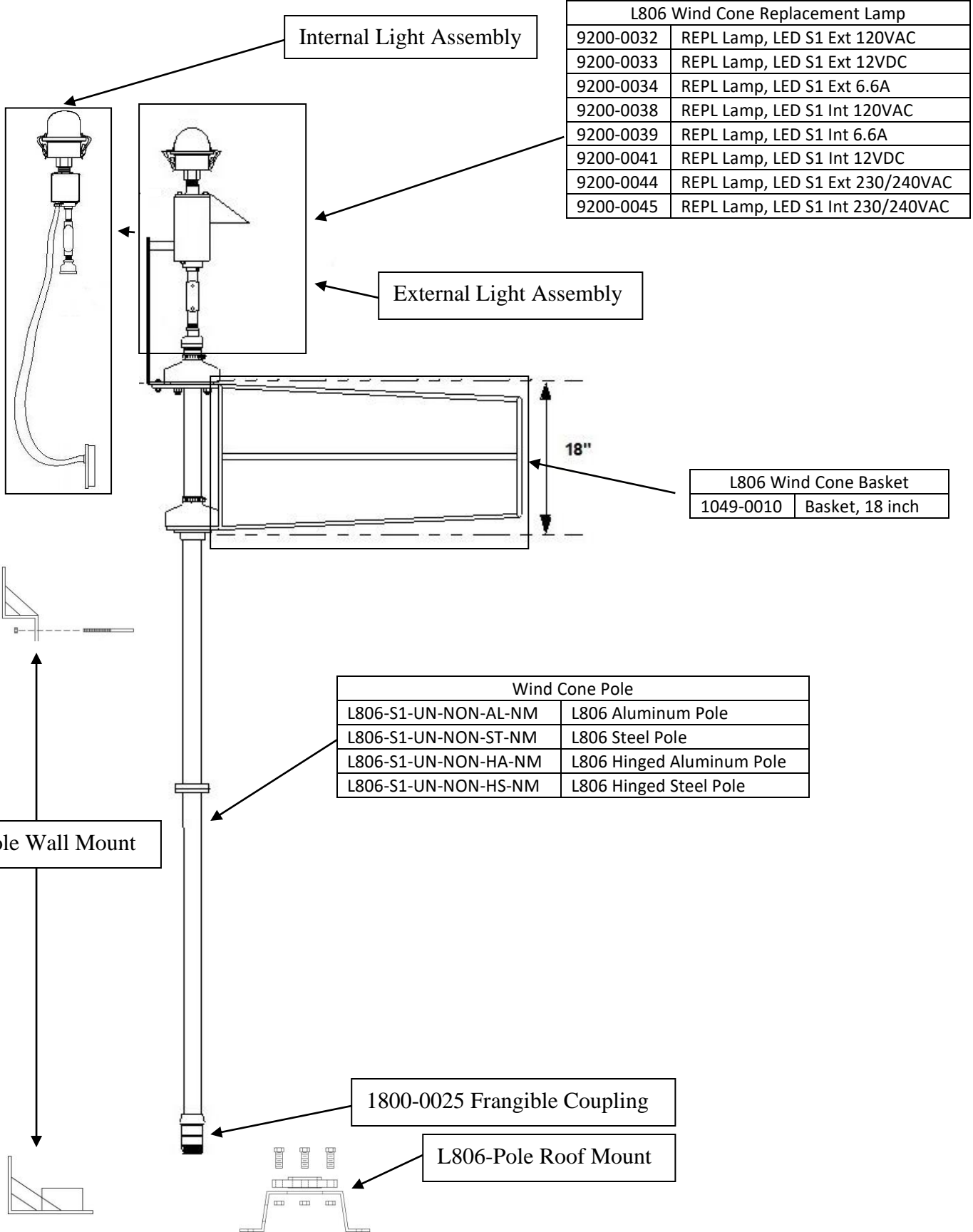

L807 Replacement Part Diagram

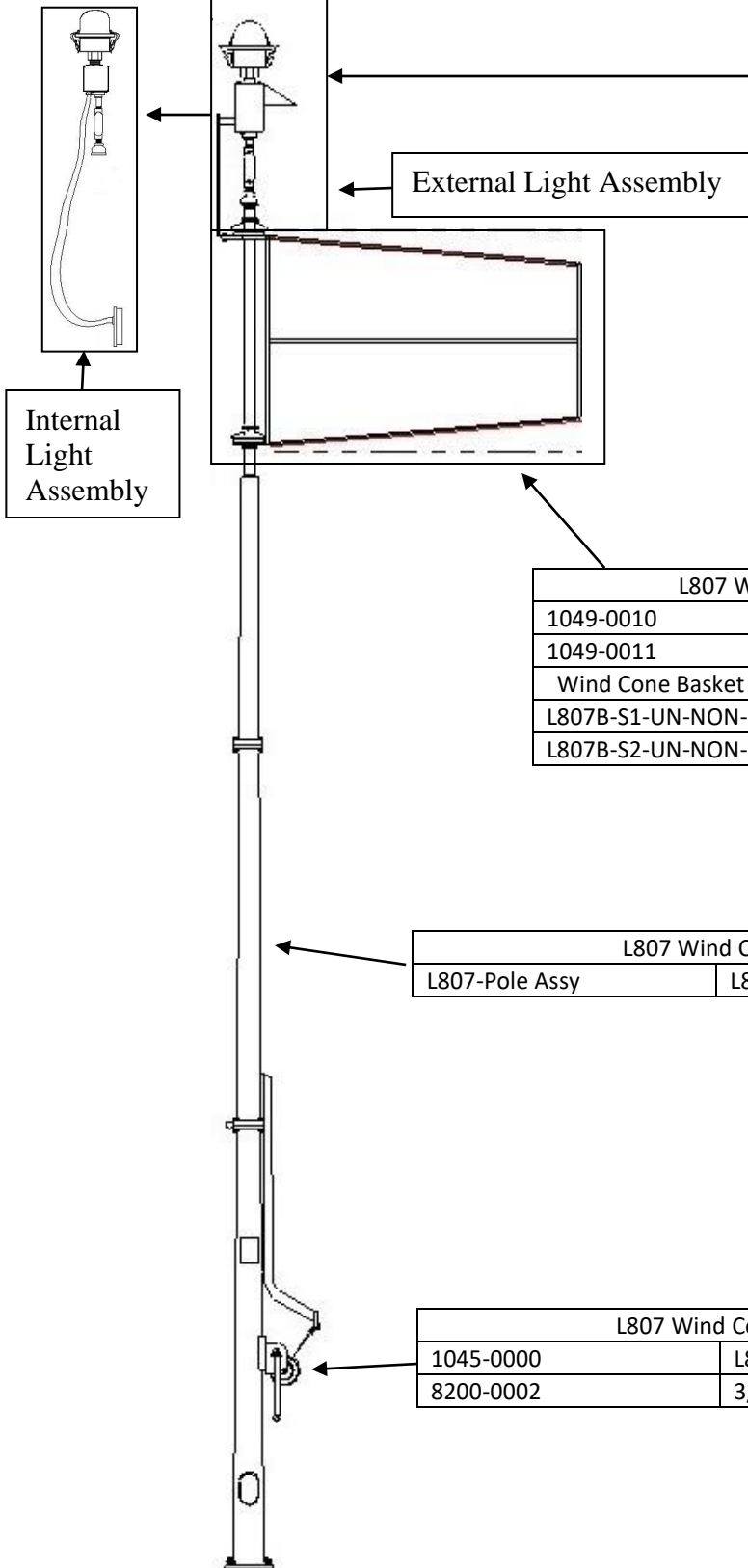

L807 Wind Cone Replacement Lamp	
9200-0031	REPL LAMP, INT LED S2 6.6 AMP
9200-0032	REPL Lamp, LED S1 Ext 120VAC
9200-0033	REPL Lamp, LED S1 Ext 12VDC
9200-0034	REPL Lamp, LED S1 Ext 6.6A
9200-0035	REPL Lamp, LED S2 Ext 120VAC
9200-0036	REPL Lamp, LED S2 Ext 12VDC
9200-0037	REPL Lamp, LED S2 Ext 6.6A
9200-0038	REPL Lamp, LED S1 Int 120VAC
9200-0039	REPL Lamp, LED S1 Int 6.6A
9200-0040	REPL Lamp, LED S2 Int 120VAC
9200-0041	REPL Lamp, LED S1 Int 12VDC
9200-0042	REPL Lamp, LED S2 Int 12VDC
9200-0043	REPL Lamp, LED S2 Ext 230/240VAC
9200-0044	REPL Lamp, LED S1 Ext 230/240VAC
9200-0045	REPL Lamp, LED S1 Int 230/240VAC
9200-0046	REPL Lamp, LED S2 Int 230/240VAC

L807 Wind Cone Basket	
1049-0010	Basket, 18 inch
1049-0011	Basket, 36 inch
Wind Cone Basket Assembly (W/Support Tube)	
L807B-S1-UN-NON-ON-N	L807B S1 Unlit
L807B-S2-UN-NON-ON-N	L807B S2 Unlit

L807 Wind Cone Pole	
L807-Pole Assy	L807 Pole Assy

L807 Wind Cone Winch	
1045-0000	L807 Pole Winch
8200-0002	3/16 SS Aircraft Cable

CHAPTER 8

Spare Parts

How to Order Parts

Spare or replacement parts can be ordered by:

- Calling Hali-Brite® at 1-800-553-6269.

Recommended Spare Parts

TABLE 6. Recommended Spare Parts List for L-806 and L-807

Description	Part Number	Quantity
Wind Sock, 36" x 12', Orange Nylon	7400-0002	1
Wind Sock, 18" x 8', Orange Nylon	7400-0000-1	1
L806 Frangible Coupling	1800-0025	1
Lamp, 6.6Amp Internal Size 2 LED	9200-0031	1
Lamp, 120V External Size 1 LED	9200-0032	1
Lamp, 12VDC External Size 1 LED	9200-0033	1
Lamp, 6.6Amp External Size 1 LED	9200-0034	1
Lamp, 120V External Size 2 LED	9200-0035	1
Lamp, 12VDC External Size 2 LED	9200-0036	1
Lamp, 6.6Amp External Size 2 LED	9200-0037	1
Lamp, 120V Internal Size 1 LED	9200-0038	1
Lamp, 6.6Amp Internal Size 1 LED	9200-0039	1
Lamp, 120V Internal Size 2 LED	9200-0040	1
Lamp, 12VDC Internal Size 1 LED	9200-0041	1
Lamp, 12VDC Internal Size 2 LED	9200-0042	1
Lamp, 230/240V External Size 2 LED	9200-0043	1
Lamp, 230/240V External Size 1 LED	9200-0044	1
Lamp, 230/240V Internal Size 1 LED	9200-0045	1
Lamp, 230/240V Internal Size 2 LED	9200-0046	1

CHAPTER 9

Wiring Diagrams

The following wiring diagrams are for the internal and external lights on the L-806 or L-807 Wind Cone. Refer to the following table to locate the correct figure.

Type	Sock Diameter	Light Type	Power	Wiring Diagram
L-806	18"	External LED	12 VDC	Figure 27 on page 47
L-806	18"	External LED	120 VAC	Figure 28 on page 48
L-806	18"	External LED	6.6 Amp	Figure 31 on page 51
L-806	18"	Internal LED	120 VAC	Figure 29 on page 49
L-806	18"	Internal LED	230/240V	Figure 29 on page 49
L-806	18"	Internal LED	6.6 Amp	Figure 31 on page 51
L-806	18"	External LED	230/240V	Figure 28 on page 48
L-806	18"	Internal LED	12 VDC	Figure 27 on page 47
L-807	18"	External LED	12 VDC	Figure 27 on page 47
L-807	18"	External LED	120 VAC	Figure 28 on page 48
L-807	18"	External LED	6.6 Amp	Figure 31 on page 51
L-807	18"	Internal LED	120 VAC	Figure 29 on page 49
L-807	18"	Internal LED	230/240V	Figure 29 on page 49
L-807	18"	Internal LED	6.6 Amp	Figure 31 on page 51
L-807	18"	External LED	230/240V	Figure 28 on page 48
L-807	18"	Internal LED	12 VDC	Figure 27 on page 47
L-807	36"	External LED	12 VDC	Figure 27 on page 47
L-807	36"	External LED	120 VAC	Figure 28 on page 48
L-807	36"	External LED	6.6 Amp	Figure 31 on page 51
L-807	36"	Internal LED	120 VAC	Figure 30 on page 50
L-807	36"	Internal LED	230/240V	Figure 30 on page 50
L-807	36"	Internal LED	6.6 Amp	Figure 31 on page 51
L-807	18"	External LED	230/240V	Figure 28 on page 48
L-807	18"	Internal LED	12 VDC	Figure 27 on page 47

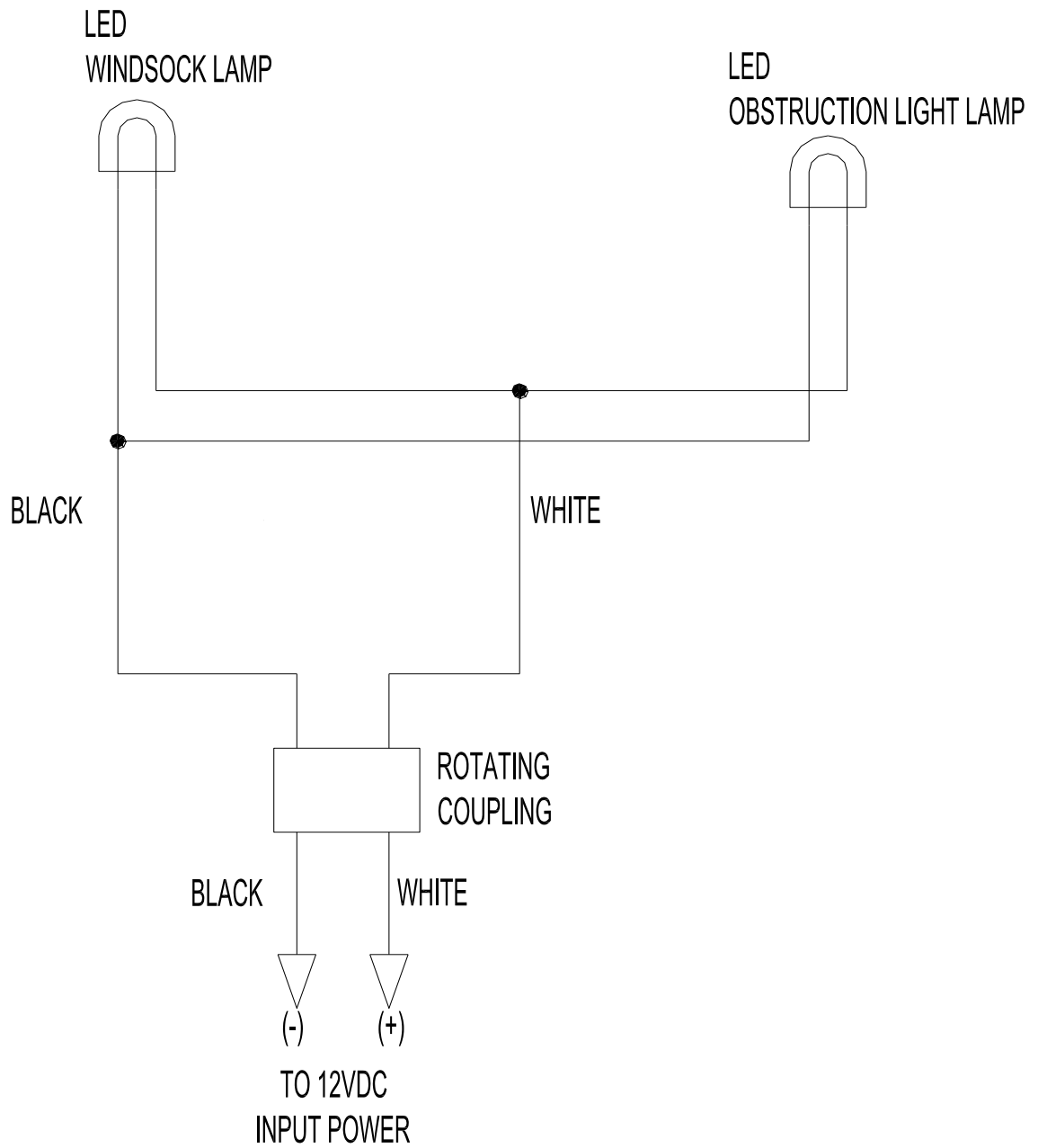

Figure 27. 12 VDC External and Internal LED Light

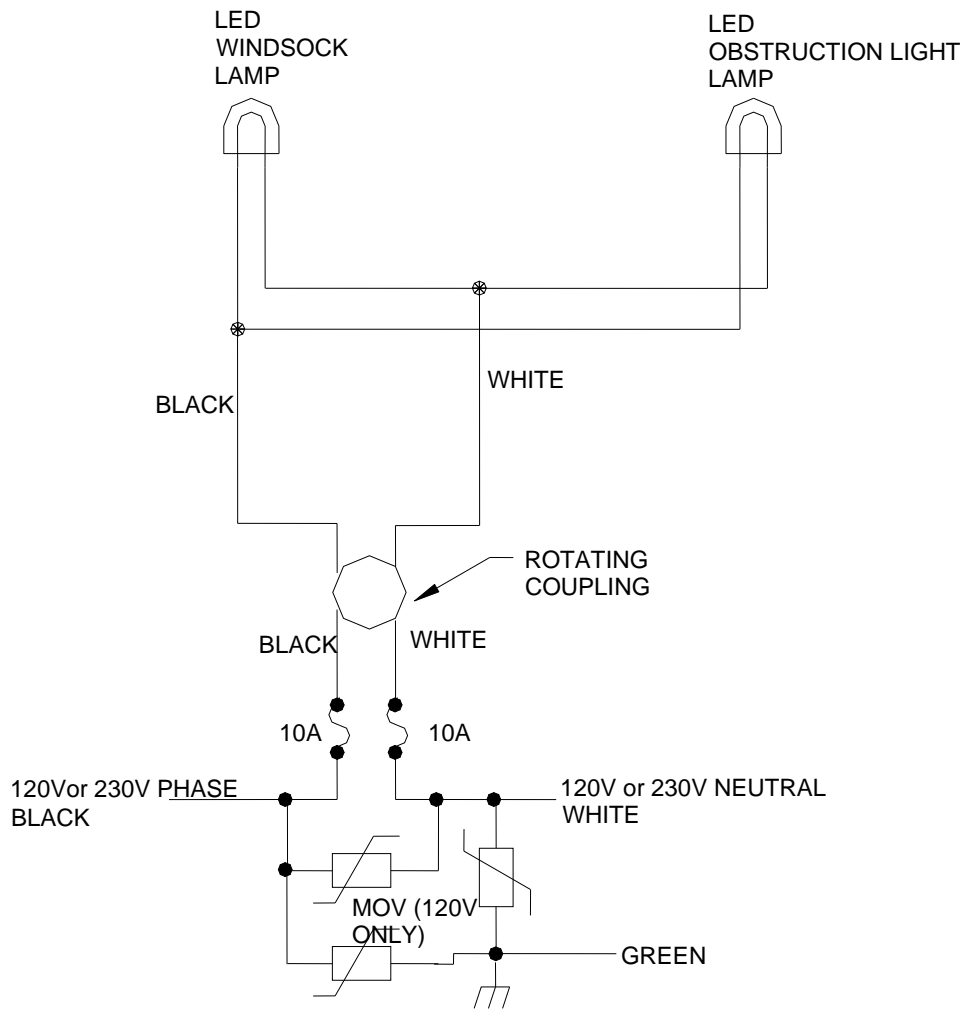

Figure 28. 120VAC and 230/240VAC 18" and 36" External LED Light

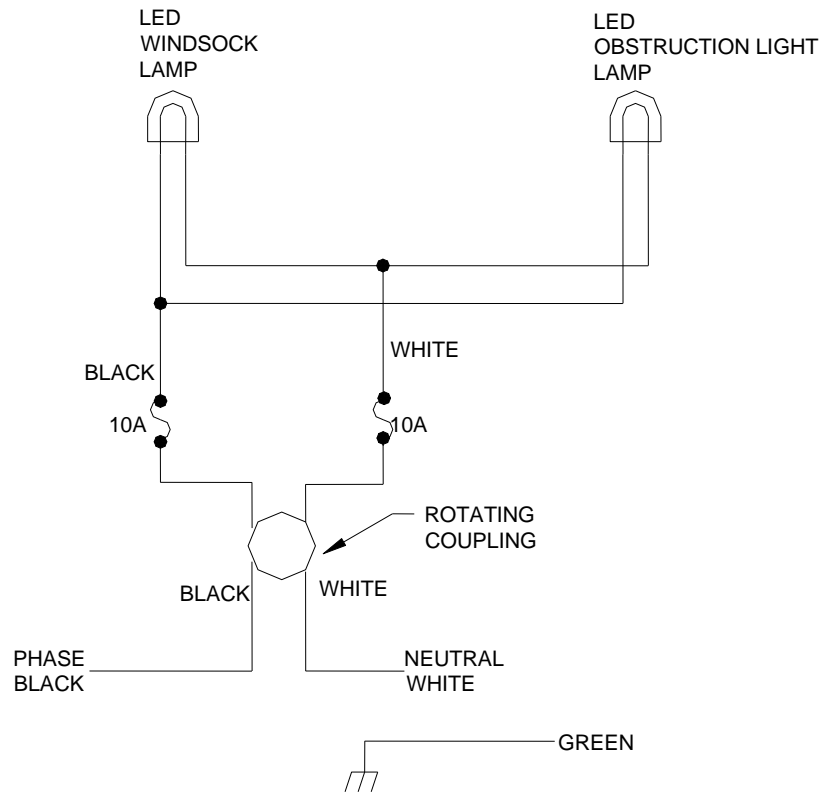

Figure 29. 120 or 230/240 VAC 18" Internal LED Light

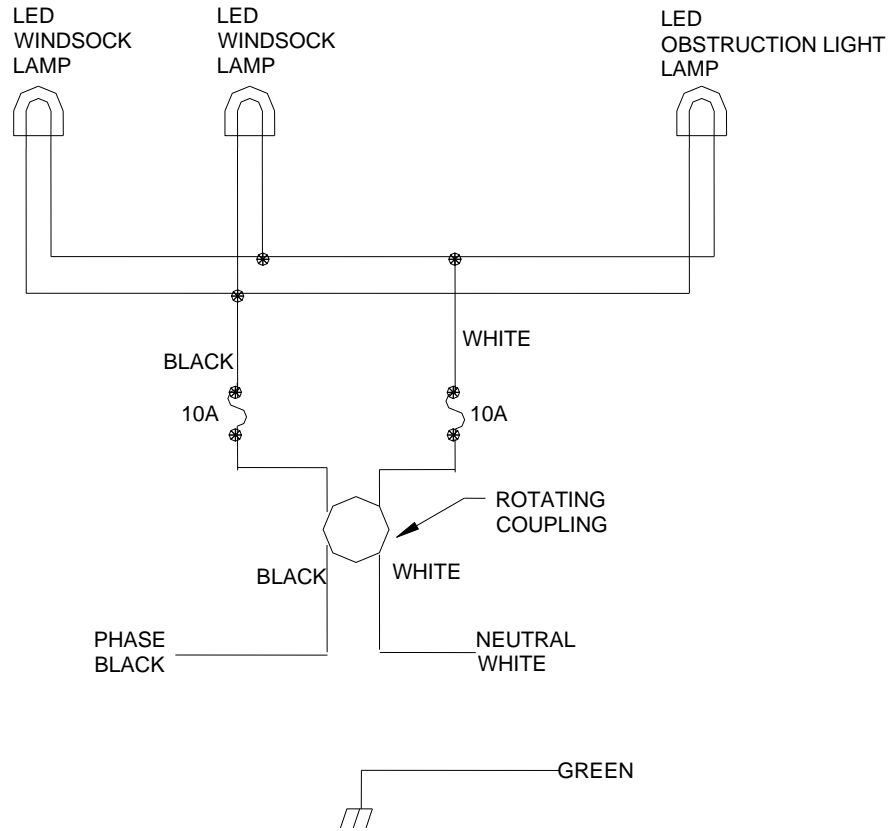

Figure 30. 120 or 230/240 VAC 36" Internal LED Light

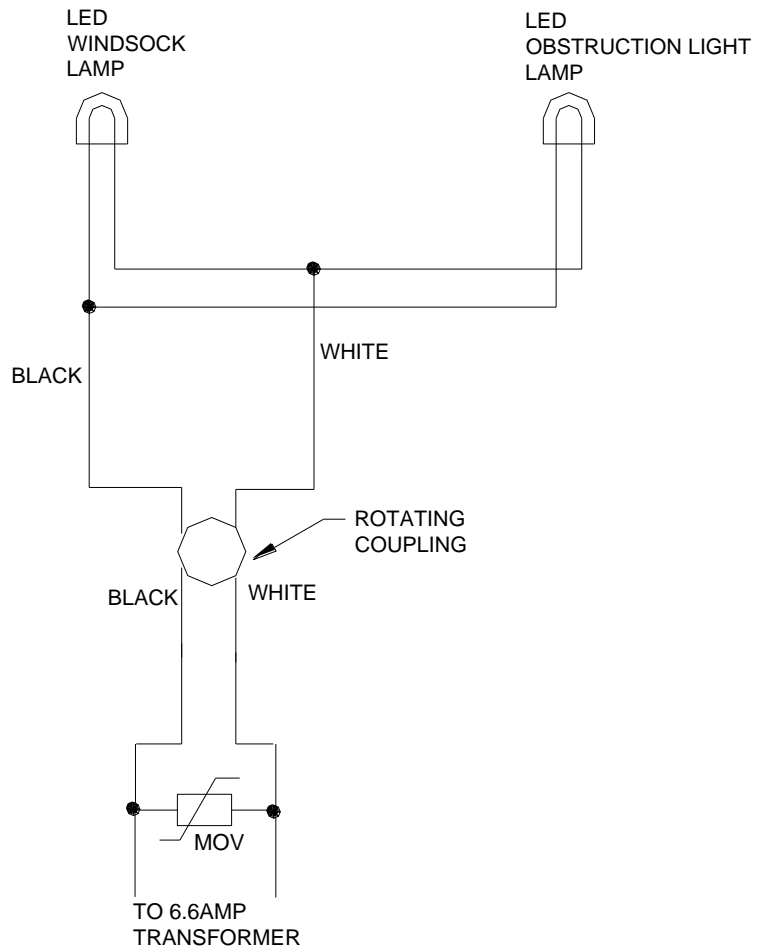

Figure 31. 6.6 Amp 18" and 36" External and Internal LED Wiring